

AIR CONDITIONER

Wall mounted type

DESIGN & TECHNICAL MANUAL

INDOOR



RSG07KPCA
RSG09KPCA
RSG12KPCA

OUTDOOR

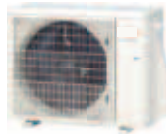

ROG07KPCA
ROG09KPCA
ROG12KPCA

Notices:

- Product specifications and design are subject to change without notice for future improvement.
- For further details, please check with our authorized dealer.

CONTENTS

Part 1. INDOOR UNIT	1
1. Specifications	2
2. Dimensions	4
2-1. Models: RSG07KPCA, RSG09KPCA, and RSG12KPCA	4
3. Wiring diagrams	6
3-1. Models: RSG07KPCA, RSG09KPCA, and RSG12KPCA	6
4. Capacity table	7
4-1. Cooling capacity.....	7
4-2. Heating capacity	8
5. Fan performance	9
5-1. Air velocity distributions.....	9
5-2. Airflow	11
6. Operation noise (sound pressure)	13
6-1. Noise level curve.....	13
6-2. Sound level check point	14
7. Safety devices	15
8. Remote controller	16
8-1. Wireless remote controller	16
9. Function settings	18
9-1. Function settings by using remote controller.....	18
9-2. Custom code setting for wireless remote controller.....	23
10. Accessories	24
11. Optional parts	25
11-1.Others	25

CONTENTS (continued)

Part 2. OUTDOOR UNIT27

1. Specifications	28
2. Dimensions	29
2-1. Models: ROG07KPCA, ROG09KPCA, and ROG12KPCA	29
3. Installation space	30
3-1. Models: ROG07KPCA, ROG09KPCA, and ROG12KPCA	30
4. Refrigerant circuit	33
4-1. Models: ROG07KPCA, ROG09KPCA, and ROG12KPCA	33
5. Wiring diagrams	34
5-1. Models: ROG07KPCA, ROG09KPCA, and ROG12KPCA	34
6. Capacity compensation rate for pipe length and height difference	35
6-1. Models: ROG07KPCA and ROG09KPCA	35
6-2. Model: ROG12KPCA	36
7. Additional charge calculation	37
7-1. Models: ROG07KPCA and ROG09KPCA	37
7-2. Model: ROG12KPCA	37
8. Airflow	38
8-1. Model: ROG07KPCA	38
8-2. Model: ROG09KPCA	38
8-3. Model: ROG12KPCA	39
9. Operation noise (sound pressure)	40
9-1. Noise level curve	40
9-2. Sound level check point	41
10. Electrical characteristics	42
11. Safety devices	43
12. Accessories	44
12-1. Models: ROG07KPCA, ROG09KPCA, and ROG12KPCA	44

Part 1. INDOOR UNIT

WALL MOUNTED TYPE:

RSG07KPCA

RSG09KPCA

RSG12KPCA

1. Specifications

Type				Wall mounted				
				Inverter heat pump				
Model name				RSG07KPCA	RSG09KPCA	RSG12KPCA		
Power supply				230 V ~ 50 Hz				
Power supply intake				Outdoor unit				
Available voltage range				198—264 V				
Capacity	Cooling	Rated	kW	2.00	2.50	3.40		
			Btu/h	6,800	8,500	11,600		
		Min.—Max.	kW	0.9—2.8	0.9—3.0	0.9—3.7		
	Heating	Rated	Btu/h	3,100—9,600	3,100—10,200	3,100—12,600		
			kW	2.50	2.80	3.80		
		Min.—Max.	Btu/h	8,500	9,500	13,000		
Input power	Cooling	Rated	kW	0.48	0.71	1.00		
				Min.—Max.	0.25—1.03	0.25—1.05	0.25—1.14	
		Heating		Rated	0.63	0.79	1.14	
	Min.—Max.			0.25—1.39	0.25—1.39	0.25—1.60		
	Fan	HIGH		W	21.5		26.9	
					12.5		14.5	
			6.3			7.1		
			3.0			3.0		
	Current	Cooling	Rated	A	2.7	3.5	4.7	
					3.2	3.8	5.6	
	EER	Cooling		kW/kW	4.17	3.52	3.40	
					3.97	3.54	3.33	
COP	Heating		kW/kW	1.9	2.1	2.6		
				77	87	92		
Sensible capacity	Cooling		kW	85	90	89		
				77	87	92		
Power factor	Cooling		%	85	90	89		
				77	87	92		
Moisture removal	Cooling		L/h (pints/h)	1.0 (1.8)	1.3 (2.30)	1.8 (3.20)		
				77	87	92		
Maximum operating current *1	Cooling		A	6.5	6.5	6.5		
				9.0	9.0	9.0		
Fan	Cooling	HIGH	m ³ /h	580	580	630		
				MED	460	460	490	
				LOW	340	340	360	
				QUIET	240	240	240	
				Heating	HIGH	580	580	630
						MED	460	460
	LOW	380	380			380		
	QUIET	260	260			260		
	Type × Q'ty					Cross flow fan × 1		
	Motor output					W	27	27
	Sound pressure level *2	Cooling	HIGH	dB (A)	45	45	46	
					MED	38	38	40
LOW					31	31	33	
QUIET					22	22	22	
Heating		HIGH	45	45	46			
			MED	40	40	40		
			LOW	36	36	35		
			QUIET	26	26	27		
Heat exchanger type		Dimensions (H × W × D)		mm	210 × 600 × 26.6			
		Fin pitch			1.3			
		Rows × Stages			2 × 10			
		Pipe type			Copper tube			
	Fin type		Aluminum					
Enclosure	Material		Polystyrene					
	Color		White Approximate color of Munsell N 9.25/					
Dimensions (H × W × D)	Net		mm	270 × 784 × 224				
	Gross			279 × 864 × 334				
Weight	Net		kg	8.0				
	Gross			11.0				
Connection pipe	Size	Liquid	mm (in)	Ø 6.35 (1/4)				
		Gas		Ø 9.52 (3/8)				
Drain hose	Method		Flare					
	Material		PP+HDPE					
Operation range	Size		mm	Ø 11.8 (I.D.), Ø 15 to Ø 16.8 (O.D.)				
	Cooling	°C		18 to 32				
Heating		%RH		80 or less				
	°C		16 to 30					
Remote controller type				Wireless				

NOTES:

- Specifications are based on the following conditions:
 - Cooling: Indoor temperature of 27 °CDB/19 °CWB, and outdoor temperature of 35 °CDB/24 °CWB.
 - Heating: Indoor temperature of 20 °CDB/15 °CWB, and outdoor temperature of 7 °CDB/6 °CWB.
 - Pipe length: 5 m, Height difference: 0 m. (Between outdoor unit and indoor unit.)
- Protective function might work when using it outside the operation range.
- *1: Maximum current is maximum value when operated within the operation range.
- *2: Sound pressure level:
 - Measured values in manufacturer's anechoic chamber.
 - Because of the surrounding sound environment, the sound levels measured in actual installation conditions might be higher than the specified values here.

Specifications for Lot10					
Model name		RSG07KPCA		RSG09KPCA	RSG12KPCA
Energy efficiency class	Cooling	A ⁺⁺			
	Heating (Average)	A ⁺			
P design	Cooling	kW	2.0 (35 °C)	2.5 (35 °C)	3.4 (35 °C)
	Heating (Average)		2.2 (-10 °C)	2.4 (-10 °C)	2.5 (-10 °C)
SEER	Cooling	kWh/kWh	6.7	6.7	6.3
SCOP	Heating (Average)		4.0	4.0	4.1
Annual energy consumption	QCE	kWh/a	104	131	189
	QHE (Average)		769	840	853
Sound power level	Cooling	HIGH	dB (A)	57	58
	Heating			58	58

2. Dimensions

2-1. Models: RSG07KPCA, RSG09KPCA, and RSG12KPCA

Unit: mm

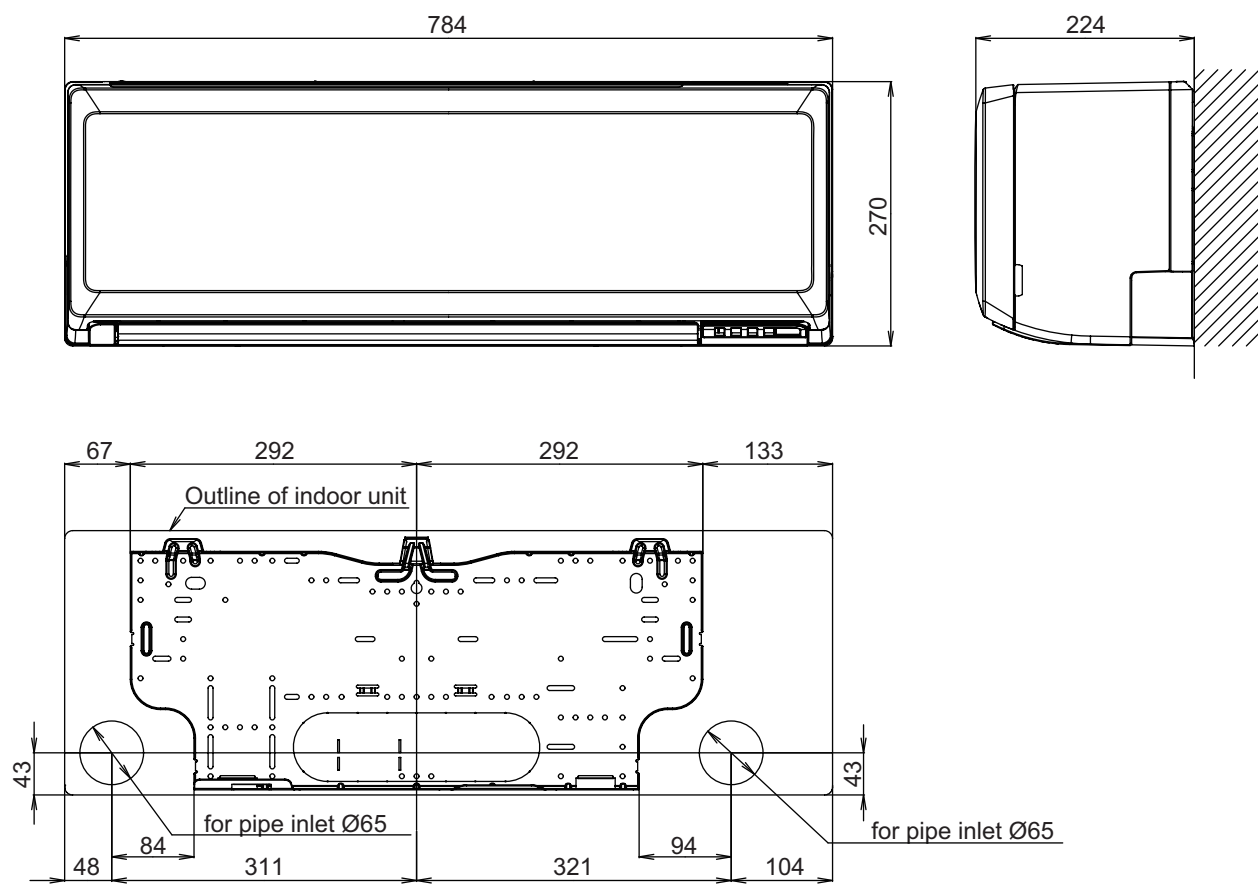

■ Installation space requirement

Provide sufficient installation space for product safety.

Unit: mm

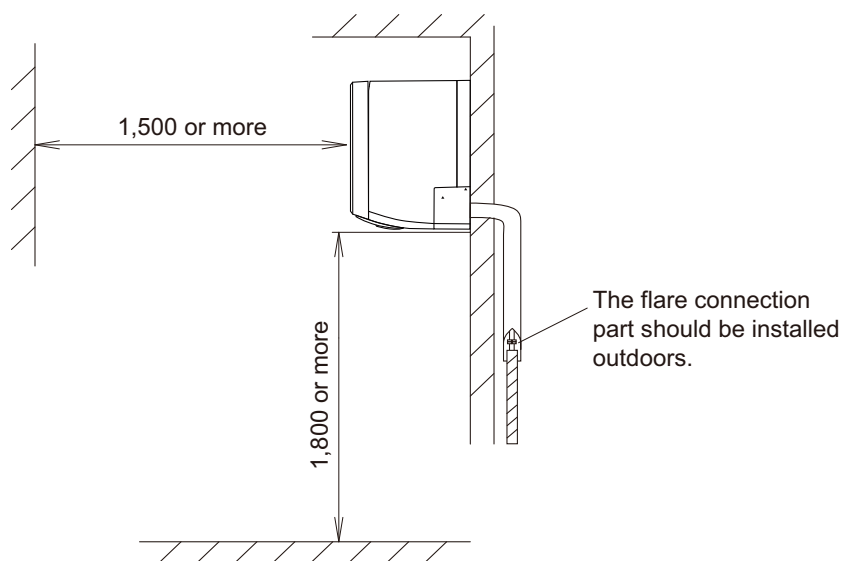
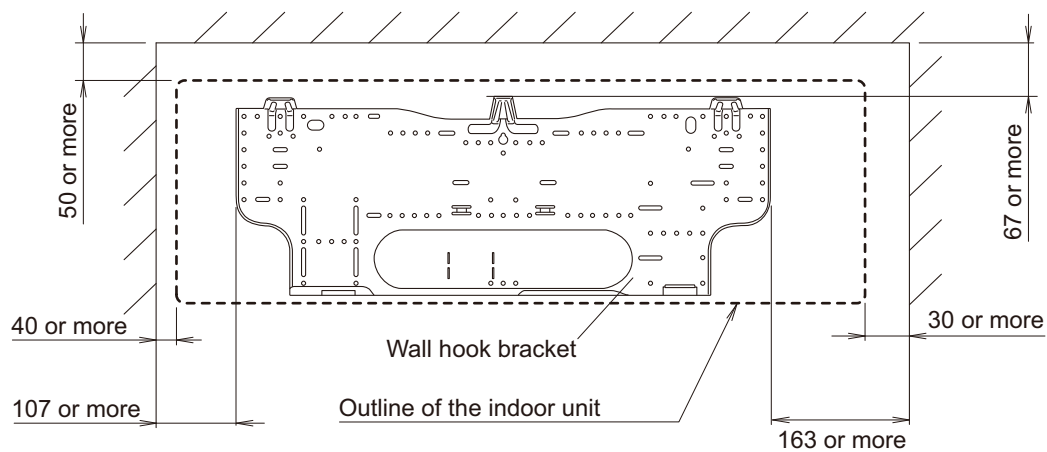

3. Wiring diagrams

3-1. Models: RSG07KPCA, RSG09KPCA, and RSG12KPCA

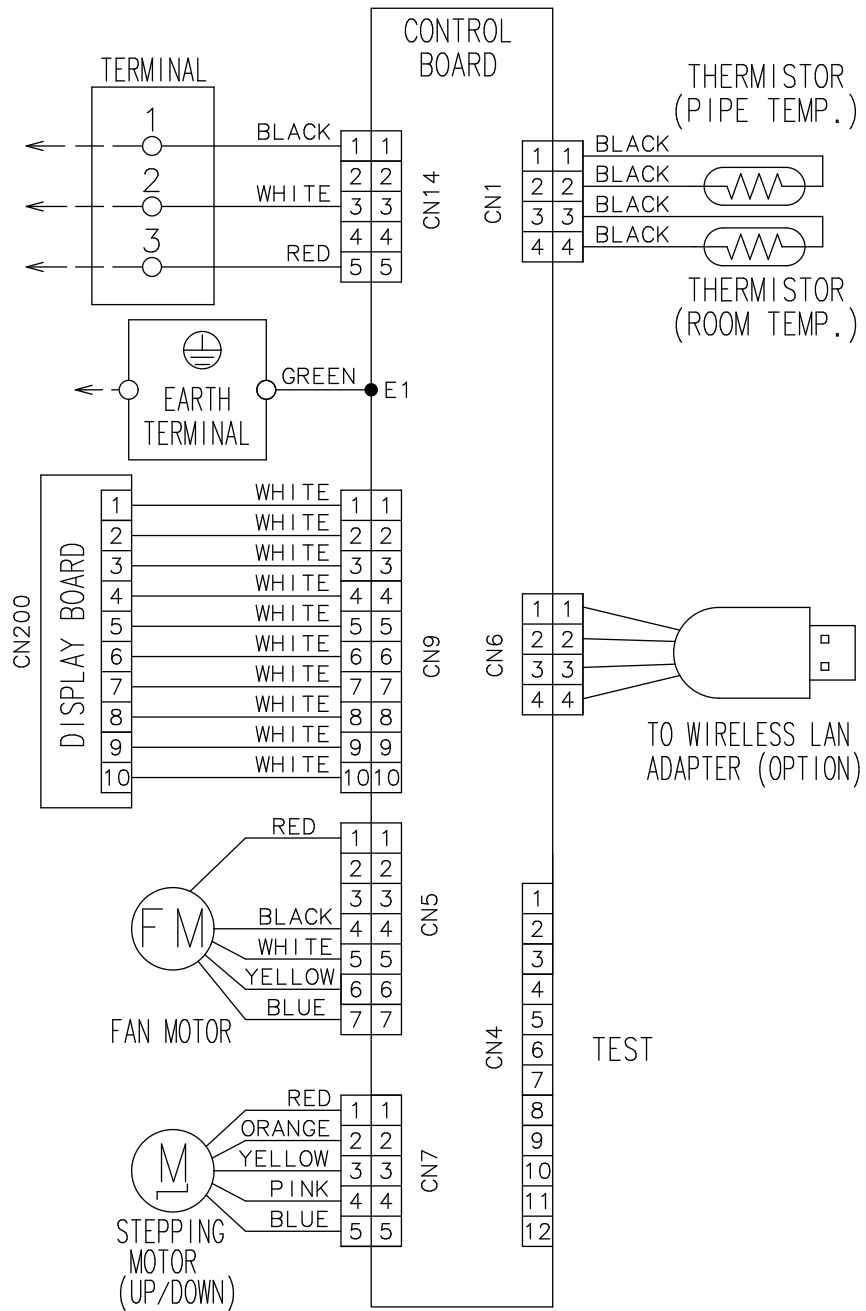

4. Capacity table

Capacity tables show each of following values calculated based on the outdoor temperature and the indoor temperature, under given Airflow Rate (AFR):

For cooling capacity: Total Capacity (TC), Sensible Heat Capacity (SHC), and Input Power (IP)

For heating capacity: Total Capacity (TC) and Input Power (IP)

4-1. Cooling capacity

■ Model: RSG07KPCA

AFR		m ³ /h																		580				
Outdoor temperature	Indoor temperature																							
	°CDB			18			21			23			25			27			29			32		
	°CWB			12			15			16			18			19			21			23		
	°CDB			TC	SHC	IP	TC	SHC	IP	TC	SHC	IP	TC	SHC	IP	TC	SHC	IP	TC	SHC	IP	TC	SHC	IP
	kW			kW			kW			kW			kW			kW			kW			kW		
-10	1.49	1.03	0.22	1.65	1.04	0.23	1.71	1.13	0.23	1.82	1.13	0.23	1.88	1.22	0.23	1.99	1.22	0.23	2.11	1.30	0.23	2.11	1.30	0.23
0	1.56	1.09	0.28	1.74	1.09	0.28	1.80	1.19	0.29	1.92	1.19	0.29	1.98	1.29	0.29	2.10	1.28	0.29	2.22	1.37	0.30	2.22	1.37	0.30
5	1.57	1.09	0.28	1.75	1.10	0.28	1.81	1.19	0.28	1.93	1.20	0.28	1.99	1.29	0.29	2.11	1.29	0.29	2.23	1.37	0.29	2.23	1.37	0.29
10	1.58	1.10	0.27	1.76	1.10	0.27	1.82	1.20	0.28	1.94	1.20	0.28	2.00	1.30	0.28	2.12	1.29	0.28	2.24	1.38	0.29	2.24	1.38	0.29
15	1.73	1.22	0.30	1.92	1.22	0.31	1.99	1.33	0.31	2.12	1.34	0.31	2.18	1.44	0.31	2.32	1.44	0.32	2.45	1.53	0.32	2.45	1.53	0.32
20	1.87	1.32	0.34	2.09	1.33	0.34	2.16	1.45	0.34	2.30	1.45	0.35	2.37	1.57	0.35	2.51	1.56	0.35	2.65	1.66	0.36	2.65	1.66	0.36
25	1.78	1.26	0.38	1.98	1.26	0.38	2.05	1.37	0.39	2.18	1.38	0.39	2.25	1.49	0.39	2.39	1.48	0.40	2.52	1.58	0.40	2.52	1.58	0.40
30	1.68	1.19	0.42	1.87	1.19	0.43	1.94	1.30	0.43	2.06	1.30	0.43	2.13	1.41	0.44	2.25	1.40	0.44	2.38	1.49	0.44	2.38	1.49	0.44
35	1.58	1.12	0.46	1.76	1.12	0.47	1.82	1.22	0.47	1.94	1.23	0.48	2.00	1.32	0.48	2.12	1.32	0.48	2.24	1.40	0.49	2.24	1.40	0.49
40	1.52	1.00	0.46	1.70	1.00	0.47	1.75	1.09	0.47	1.87	1.09	0.48	1.93	1.18	0.48	2.04	1.17	0.48	2.16	1.25	0.49	2.16	1.25	0.49
46	1.47	0.92	0.46	1.64	0.93	0.47	1.69	1.01	0.47	1.80	1.01	0.48	1.86	1.09	0.48	1.97	1.09	0.48	2.08	1.16	0.49	2.08	1.16	0.49

■ Model: RSG09KPCA

AFR		m ³ /h																		580				
Outdoor temperature	Indoor temperature																							
	°CDB			18			21			23			25			27			29			32		
	°CWB			12			15			16			18			19			21			23		
	°CDB			TC	SHC	IP	TC	SHC	IP	TC	SHC	IP	TC	SHC	IP	TC	SHC	IP	TC	SHC	IP	TC	SHC	IP
	kW			kW			kW			kW			kW			kW			kW			kW		
-10	1.82	1.25	0.25	2.03	1.26	0.25	2.10	1.36	0.25	2.24	1.37	0.26	2.31	1.48	0.26	2.45	1.47	0.26	2.59	1.57	0.26	2.59	1.57	0.26
0	1.91	1.31	0.34	2.13	1.31	0.35	2.20	1.43	0.35	2.35	1.43	0.35	2.42	1.55	0.36	2.57	1.54	0.36	2.71	1.64	0.36	2.71	1.64	0.36
5	1.88	1.28	0.33	2.09	1.29	0.33	2.16	1.40	0.33	2.30	1.41	0.34	2.38	1.52	0.34	2.52	1.51	0.34	2.66	1.61	0.34	2.66	1.61	0.34
10	1.84	1.26	0.31	2.05	1.27	0.31	2.12	1.38	0.32	2.26	1.38	0.32	2.33	1.49	0.32	2.47	1.49	0.32	2.61	1.58	0.33	2.61	1.58	0.33
15	2.09	1.21	0.40	2.33	1.21	0.41	2.41	1.32	0.41	2.57	1.32	0.42	2.65	1.43	0.42	2.80	1.43	0.42	2.96	1.52	0.43	2.96	1.52	0.43
20	2.34	1.63	0.50	2.61	1.63	0.51	2.70	1.78	0.51	2.87	1.78	0.51	2.96	1.93	0.52	3.14	1.92	0.52	3.32	2.04	0.53	3.32	2.04	0.53
25	2.22	1.54	0.56	2.48	1.55	0.57	2.56	1.69	0.57	2.73	1.69	0.58	2.81	1.83	0.58	2.98	1.82	0.59	3.15	1.94	0.59	3.15	1.94	0.59
30	2.10	1.45	0.62	2.34	1.46	0.63	2.42	1.59	0.63	2.58	1.60	0.64	2.66	1.72	0.64	2.82	1.72	0.65	2.98	1.83	0.66	2.98	1.83	0.66
35	1.98	1.37	0.69	2.20	1.38	0.70	2.28	1.50	0.70	2.43	1.50	0.71	2.50	1.62	0.71	2.65	1.61	0.72	2.80	1.72	0.72	2.80	1.72	0.72
40	1.90	1.22	0.68	2.12	1.23	0.70	2.19	1.33	0.70	2.34	1.34	0.71	2.41	1.44	0.71	2.55	1.44	0.72	2.70	1.53	0.72	2.70	1.53	0.72
46	1.84	1.13	0.68	2.04	1.14	0.69	2.11	1.24	0.70	2.25	1.24	0.70	2.32	1.34	0.71	2.46	1.33	0.71	2.60	1.42	0.72	2.60	1.42	0.72

■ Model: RSG12KPCA

AFR		m ³ /h																		630				
Outdoor temperature	Indoor temperature																							
	°CDB			18			21			23			25			27			29			32		
	°CWB			12			15			16			18			19			21			23		
	°CDB			TC	SHC	IP	TC	SHC	IP	TC	SHC	IP	TC	SHC	IP	TC	SHC	IP	TC	SHC	IP	TC	SHC	IP
	kW			kW			kW			kW			kW			kW			kW			kW		
-10	2.65	1.79	0.41	2.96	1.80	0.41	3.06	1.95	0.41	3.26	1.96	0.42	3.36	2.12	0.42	3.56	2.11	0.43	3.76	2.25	0.43	3.76	2.25	0.43
0	2.57	1.73	0.43	2.87	1.74	0.44	2.97	1.89	0.44	3.16	1.90	0.44	3.26	2.05	0.45	3.45	2.04	0.45	3.65	2.18	0.46	3.65	2.18	0.46
5	2.54	1.71	0.48	2.83	1.72	0.49	2.93	1.87	0.49	3.12	1.88	0.50	3.21	2.03	0.50	3.41	2.02	0.50	3.60	2.15	0.51	3.60	2.15	0.51
10	2.50	1.69	0.53	2.79	1.70	0.54	2.88	1.84	0.54	3.07	1.85	0.55	3.17	2.00	0.55	3.36	1.99	0.56	3.55	2.12	0.56	3.55	2.12	0.56
15	2.84	1.63	0.62	3.17	1.64	0.63	3.28	1.78	0.63	3.49	1.78	0.64	3.60	1.93	0.64	3.82	1.92	0.65	4.03	2.04	0.65	4.03	2.04	0.65
20	3.18	2.18	0.70	3.55	2.19	0.71	3.67	2.39	0.72	3.91	2.39	0.72	4.03	2.59	0.73	4.27	2.57	0.73	4.51	2.74	0.74	4.51	2.74	0.74
25	3.02	2.07	0.79	3.37	2.08	0.80	3.48	2.27	0.81	3.71	2.27	0.81	3.83	2.45	0.82	4.06	2.44	0.83	4.28	2.60	0.83	4.28	2.60	0.83
30	2.86	1.96	0.88	3.18	1.97	0.89	3.29	2.14	0.89	3.51	2.15	0.90	3.62	2.32	0.91	3.83	2.31	0.92	4.05	2.46	0.93	4.05	2.46	0.93
35	2.69	1.84	0.97	2.99	1.85	0.98	3.09	2.01	0.99	3.30	2.02	1.00	3.40	2.18	1.00	3.60	2.17	1.01	3.81	2.31	1.02	3.81	2.31	1.02
40	2.39	1.64	0.96	2.67	1.65	0.98	2.76	1.79	0.98	2.94	1.80	0.99	3.03	1.94	1.00	3.21	1.94	1.01	3.39	2.06	1.02	3.39	2.06	1.02
46	2.22	1.52	0.96	2.47	1.53	0.98	2.56	1.66	0.98	2.73	1.67	0.99	2.81	1.80	1.00	2.98	1.80	1.01	3.15	1.91	1.02	3.15	1.91	1.02

4-2. Heating capacity

NOTE: Values mentioned in the table are calculated based on the maximum capacity.

■ Model: RSG07KPCA

AFR	m ³ /h	580
-----	-------------------	-----

			Indoor temperature														
			16			18			20			22			24		
			°CDB	°CWB	TC	IP	TC	IP	TC	IP	TC	IP	TC	IP			
Outdoor temperature	-15	-16			1.84	0.88	1.83	0.90	1.79	0.92	1.75	0.94	1.70	0.96			
	-10	-11	2.14	0.93	2.09	0.95	2.04	0.97	1.98	0.99	1.93	1.01					
	-5	-7	2.47	1.01	2.41	1.03	2.36	1.06	2.30	1.08	2.24	1.10					
	0	-2	2.93	1.15	2.86	1.17	2.79	1.20	2.72	1.22	2.65	1.24					
	5	3	3.31	1.28	3.31	1.31	3.23	1.33	3.15	1.36	3.06	1.39					
	7	6	3.47	1.33	3.44	1.36	3.40	1.39	3.32	1.42	3.23	1.45					
	10	8	3.74	1.38	3.65	1.41	3.56	1.44	3.47	1.47	3.38	1.50					
	15	10	3.81	1.39	3.72	1.42	3.63	1.45	3.54	1.48	3.45	1.51					
	20	15	3.68	1.09	3.59	1.12	3.50	1.14	3.41	1.16	3.33	1.18					
	24	18	3.89	1.09	3.79	1.12	3.70	1.14	3.61	1.16	3.52	1.18					

■ Model: RSG09KPCA

AFR	m ³ /h	580
-----	-------------------	-----

			Indoor temperature														
			16			18			20			22			24		
			°CDB	°CWB	TC	IP	TC	IP	TC	IP	TC	IP	TC	IP			
Outdoor temperature	-15	-16			2.12	0.88	2.12	0.90	2.09	0.92	2.10	0.94	2.08	0.96			
	-10	-11	2.53	0.89	2.47	0.91	2.41	0.93	2.34	0.95	2.28	0.96					
	-5	-7	2.85	0.96	2.78	0.98	2.71	1.00	2.65	1.02	2.58	1.04					
	0	-2	3.33	1.11	3.25	1.14	3.17	1.16	3.09	1.18	3.01	1.21					
	5	3	3.80	1.27	3.71	1.30	3.62	1.32	3.53	1.35	3.44	1.38					
	7	6	3.99	1.33	3.90	1.36	3.80	1.39	3.71	1.42	3.61	1.45					
	10	8	4.13	1.38	4.03	1.41	3.94	1.44	3.84	1.47	3.74	1.50					
	15	10	4.16	1.39	4.06	1.42	3.96	1.45	3.86	1.48	3.77	1.51					
	20	15	3.99	1.09	3.90	1.12	3.80	1.14	3.71	1.16	3.61	1.18					
	24	18	4.10	1.09	4.00	1.12	3.90	1.14	3.80	1.16	3.71	1.18					

■ Model: RSG12KPCA

AFR	m ³ /h	630
-----	-------------------	-----

			Indoor temperature														
			16			18			20			22			24		
			°CDB	°CWB	TC	IP	TC	IP	TC	IP	TC	IP	TC	IP			
Outdoor temperature	-15	-16			2.73	1.03	2.67	1.05	2.60	1.07	2.54	1.10	2.47	1.12			
	-10	-11	2.91	1.08	2.85	1.10	2.78	1.12	2.71	1.14	2.64	1.17					
	-5	-7	3.31	1.17	3.23	1.19	3.15	1.21	3.08	1.24	3.00	1.26					
	0	-2	4.03	1.32	3.94	1.35	3.84	1.38	3.74	1.40	3.65	1.43					
	5	3	4.75	1.47	4.64	1.51	4.53	1.54	4.41	1.57	4.30	1.60					
	7	6	5.04	1.54	4.92	1.57	4.80	1.60	4.68	1.63	4.56	1.66					
	10	8	4.61	1.38	4.50	1.41	4.39	1.44	4.28	1.47	4.17	1.50					
	15	10	4.73	1.39	4.62	1.42	4.50	1.45	4.39	1.48	4.28	1.51					
	20	15	4.52	1.30	4.41	1.32	4.30	1.35	4.19	1.38	4.09	1.40					
	24	18	4.62	1.28	4.51	1.30	4.40	1.33	4.29	1.36	4.18	1.38					

5. Fan performance

5-1. Air velocity distributions

■ Models: RSG07KPCA and RSG09KPCA

Measuring conditions	Fan speed	Operation mode
	HIGH	FAN

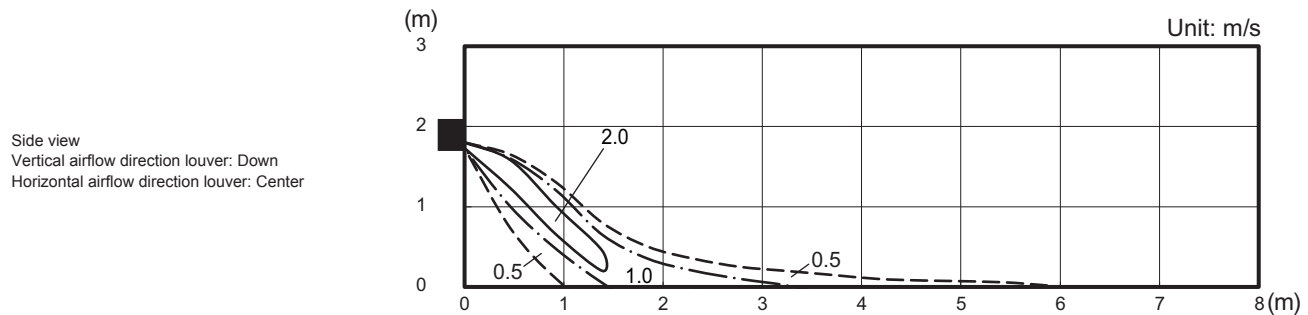
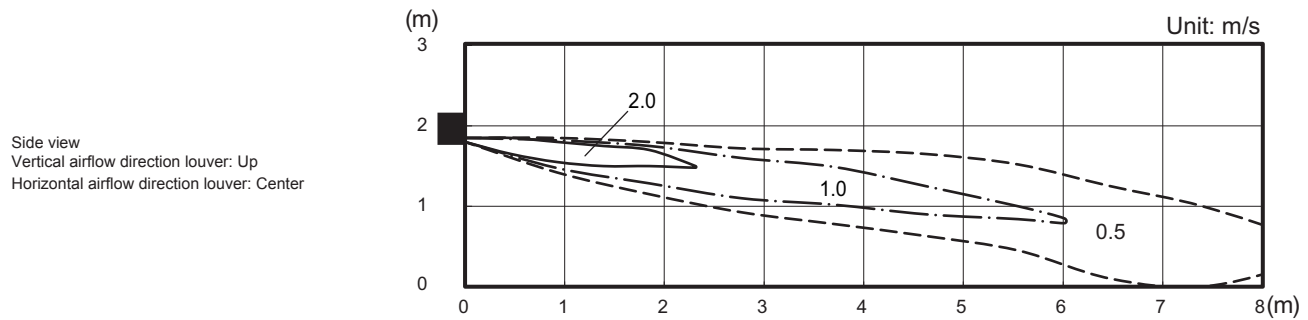
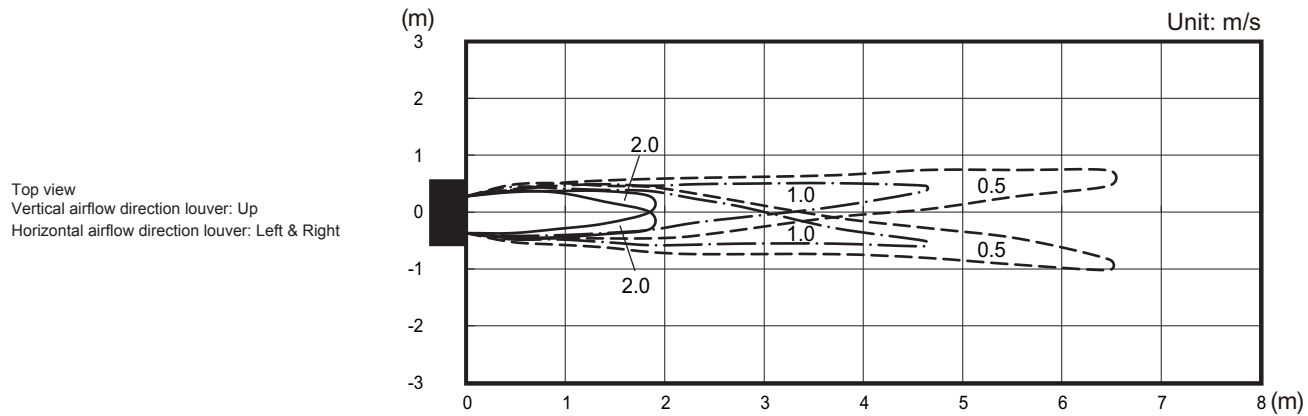
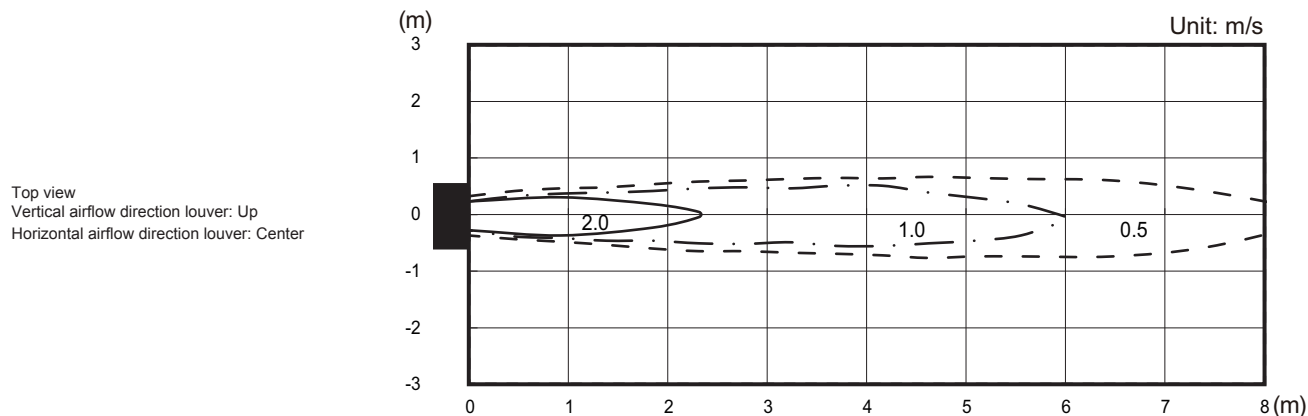

Model: RSG12KPCA

Measuring conditions	Fan speed	Operation mode
	HIGH	FAN

Top view
Vertical airflow direction louver: Up
Horizontal airflow direction louver: Center

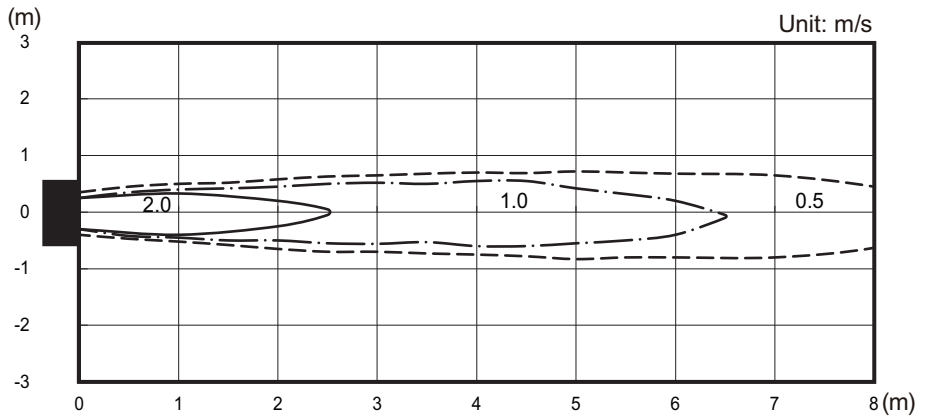

Top view
Vertical airflow direction louver: Up
Horizontal airflow direction louver: Left & Right

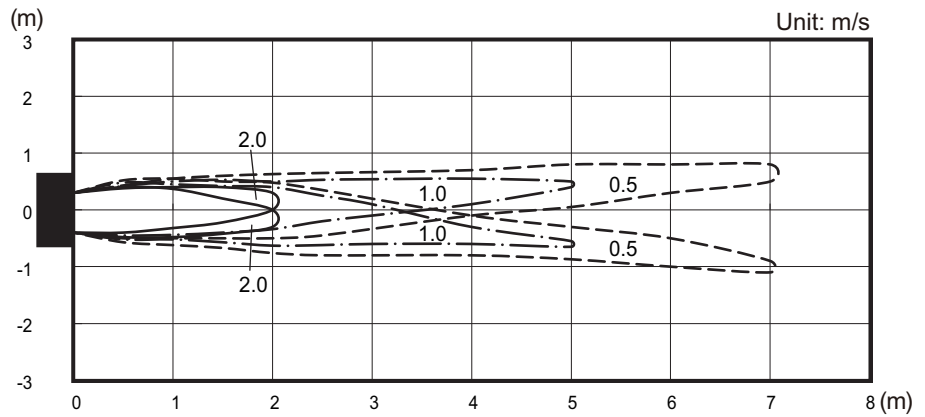

Side view
Vertical airflow direction louver: Up
Horizontal airflow direction louver: Center

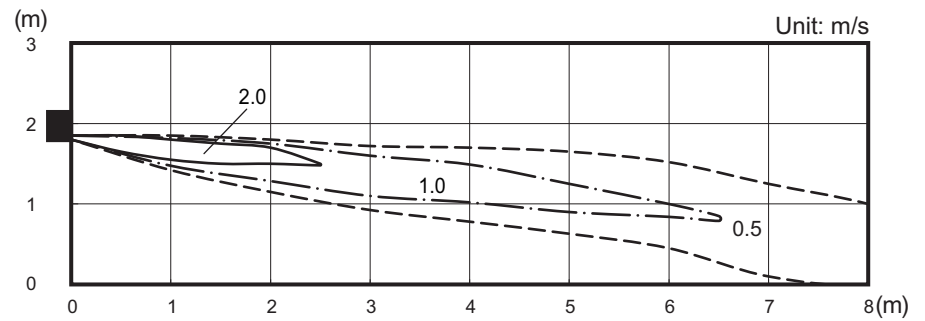

Side view
Vertical airflow direction louver: Down
Horizontal airflow direction louver: Center

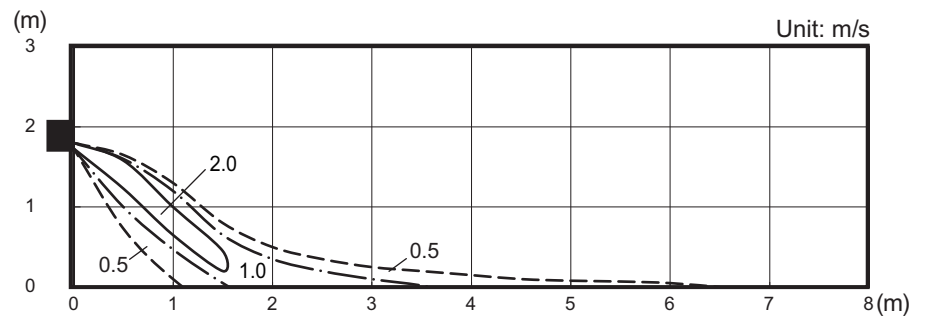

5-2. Airflow

■ Models: RSG07KPCA and RSG09KPCA

● Cooling

Fan speed	Airflow	
HIGH	m ³ /h	580
	l/s	161
	CFM	341
MED	m ³ /h	460
	l/s	128
	CFM	271
LOW	m ³ /h	340
	l/s	94
	CFM	200
QUIET	m ³ /h	240
	l/s	67
	CFM	141

● Heating

Fan speed	Airflow	
HIGH	m ³ /h	580
	l/s	161
	CFM	341
MED	m ³ /h	460
	l/s	128
	CFM	271
LOW	m ³ /h	380
	l/s	106
	CFM	224
QUIET	m ³ /h	260
	l/s	72
	CFM	153

■ Model: RSG12KPCA

● Cooling

Fan speed	Airflow	
HIGH	m ³ /h	630
	l/s	175
	CFM	371
MED	m ³ /h	490
	l/s	136
	CFM	288
LOW	m ³ /h	360
	l/s	100
	CFM	212
QUIET	m ³ /h	240
	l/s	67
	CFM	141

● Heating

Fan speed	Airflow	
HIGH	m ³ /h	630
	l/s	175
	CFM	371
MED	m ³ /h	490
	l/s	136
	CFM	288
LOW	m ³ /h	380
	l/s	106
	CFM	224
QUIET	m ³ /h	260
	l/s	72
	CFM	153

6. Operation noise (sound pressure)

6-1. Noise level curve

Models: RSG07KPCA and RSG09KPCA

Cooling

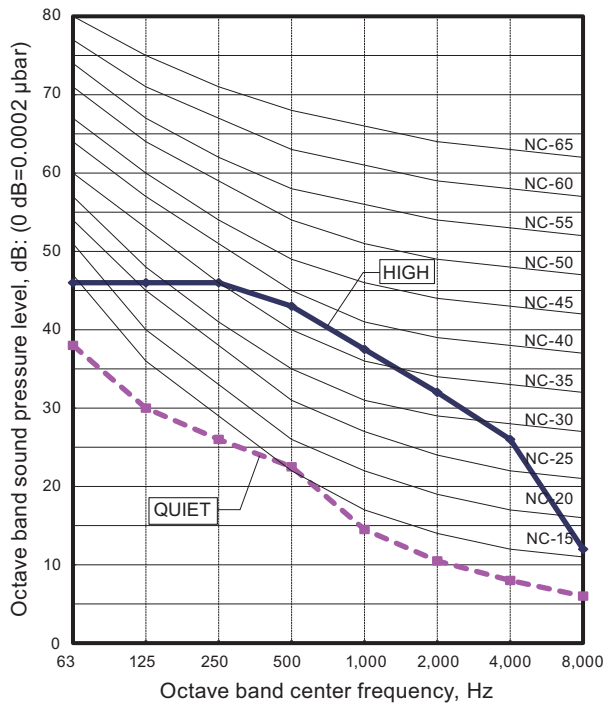

Heating

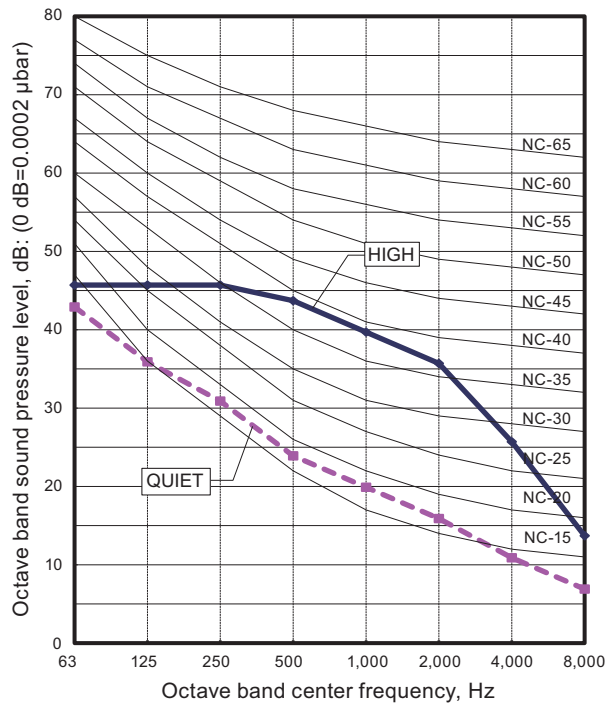

Model: RSG12KPCA

Cooling

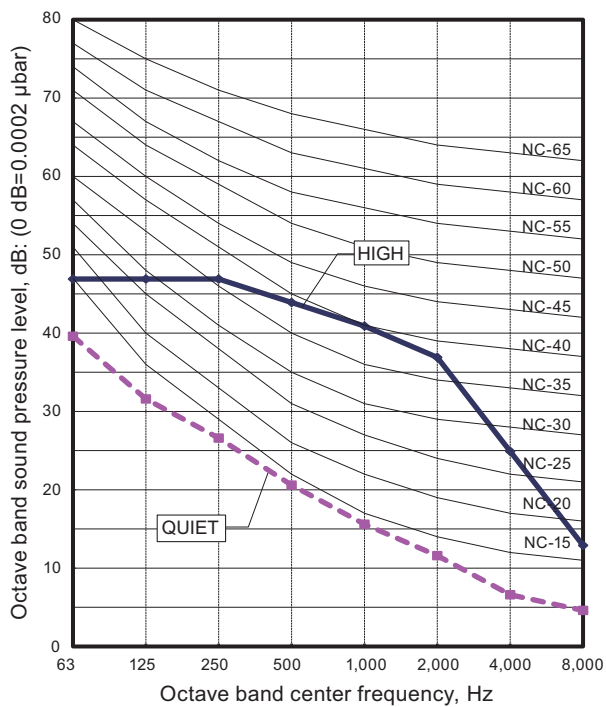

Heating

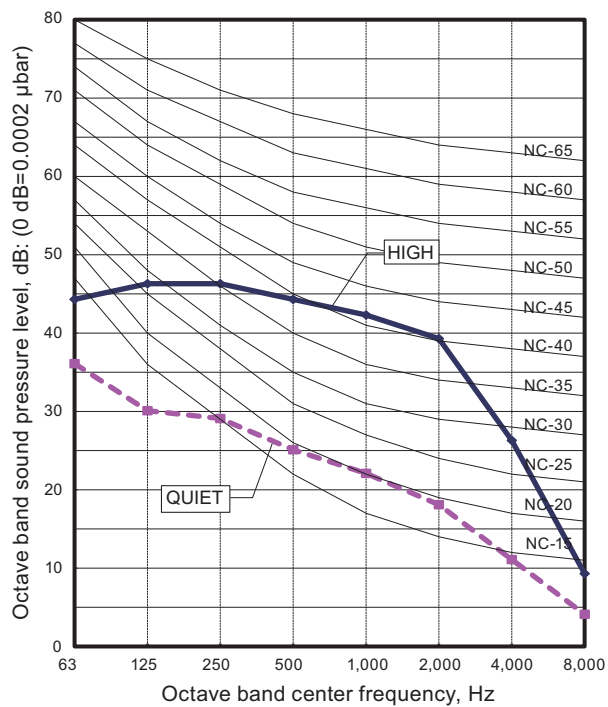

6-2. Sound level check point

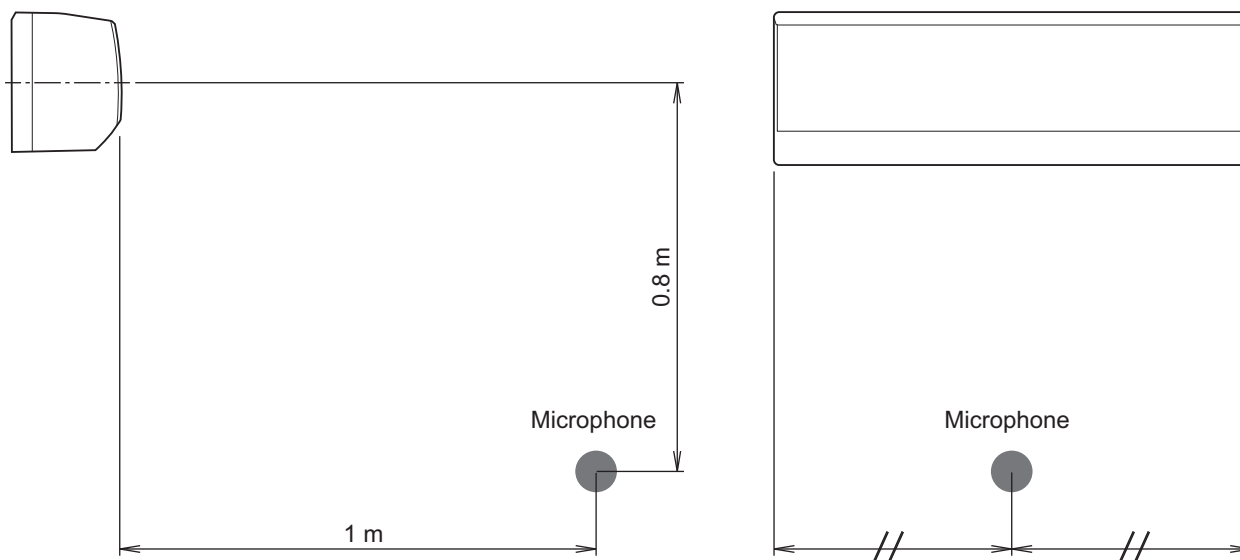

NOTE: Detailed shape of the actual indoor unit might be slightly different from the one illustrated above.

7. Safety devices

Type of protection	Protection form		Model		
			RSG07KPCA	RSG09KPCA	RSG12KPCA
Circuit protection	Current fuse (PCB*)		250 V, 3.15 A		
Fan motor protection	Thermistor protection	Activate	More than 170 °C Fan motor stop		
		Reset	145 °C or less Fan motor restart		

*PCB: Printed Circuit Board

8. Remote controller

8-1. Wireless remote controller

Overview

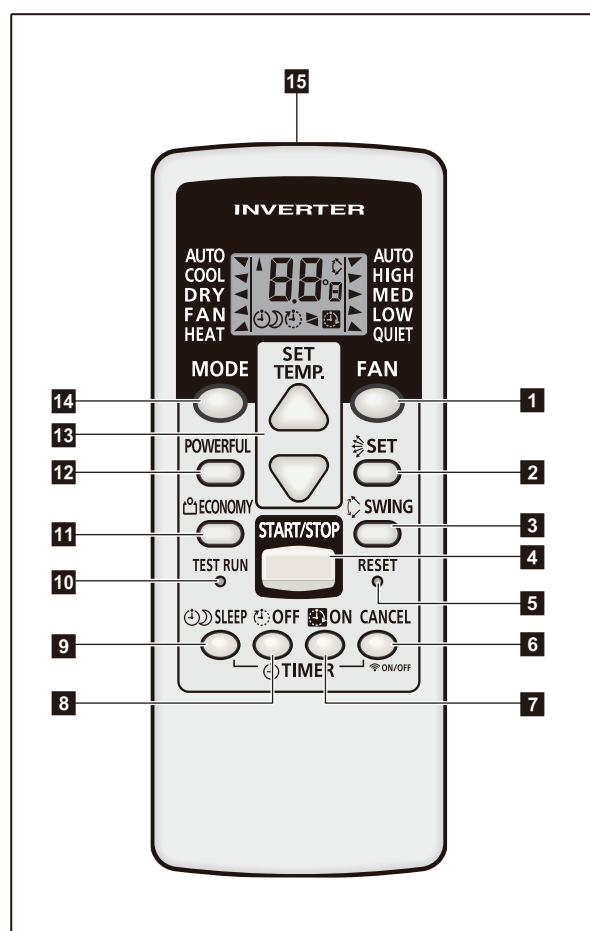

- 1 FAN button
- 2 SET button
- 3 SWING button
- 4 START/STOP button
- 5 RESET button
- 6 TIMER CANCEL/W-LAN ON/OFF button
- 7 ON TIMER/W-LAN SET button
- 8 OFF TIMER button
- 9 SLEEP TIMER button
- 10 TEST RUN button
 - Used only when installing the air conditioner, and should not be used under normal conditions, as it will cause the indoor unit's thermostat malfunction.
 - If this button is pressed during normal operation, the indoor unit will switch to test operation mode, and the operation indicator lamp and the timer indicator lamp on the indoor unit will begin to flash simultaneously.
 - To stop the test operation mode, press the START/STOP button. Then, the air conditioner stops the operation.

- 11 ECONOMY button
- 12 POWERFUL button
- 13 SET TEMP. (temperature) (▲ / ▼) button
 - Sets desired temperature.
 - Sets remote controller custom code.
- 14 MODE button
 - Switches operation mode (AUTO, COOL, DRY, FAN, and HEAT).
 - Starts/ends the remote controller custom code (max. 4 types) change.

- 15 Signal transmitter
- 16 Operating mode indicator
- 17 Signal transmit indicator
- 18 Temperature and time indicator
 - Displays set temperature.
 - In timer setting, it displays the timer time. After finishing the timer setting, set temperature will reappear.

- 19 Swing indicator
- 20 Fan speed indicator
- 21 Timer mode indicator

- Sleep timer
- OFF timer
- OFF-ON timer
- ON-OFF timer
- ON timer

Display panel

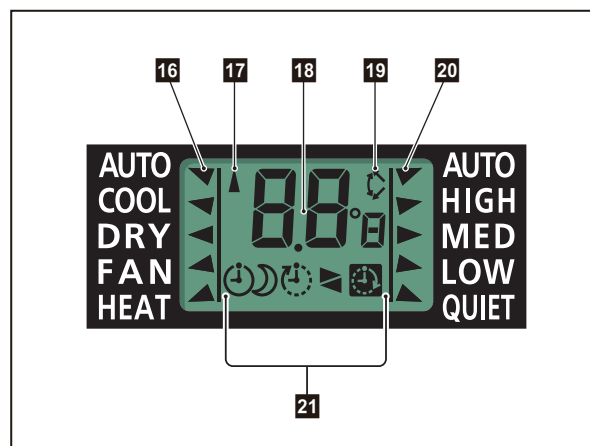

NOTE: Functions may differ by type of the indoor unit. For details, refer to the operation manual.

■ Specifications

● Controller

Unit: mm

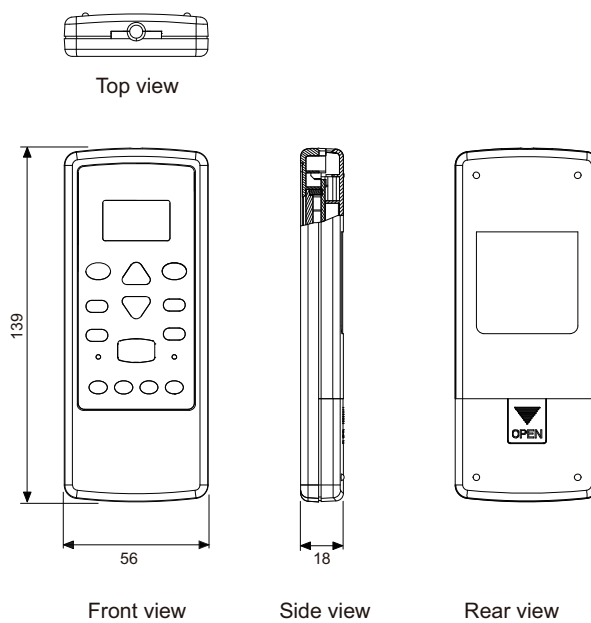

Size (H × W × D)	mm	139 × 56 × 18
Weight	g	70 (without batteries)

9. Function settings

To adjust the functions of this product according to the installation environment, various types of function settings are available.

NOTE: Incorrect settings can cause a product malfunction.

9-1. Function settings by using remote controller

Some function settings can be changed on the remote controller. After confirming the setting procedure and the content of each function setting, select appropriate functions for your installation environment.

■ Setting procedure by using wireless remote controller

The function number and the associated setting value are displayed on the LCD of the remote controller. Follow the instructions written in the local setup procedure supplied with the remote controller, and select appropriate setting according to the installation environment.

Before connecting the power supply of the indoor unit, reconfirm following items:

- Piping air tight test and vacuuming have been performed firmly.
- There is no wiring mistake.

Then, connect the power supply of indoor unit.

Entering function setting mode:

While pressing the FAN button and SET TEMP. (▲) button simultaneously, press the RESET button to enter the function setting mode.

STEP 1: Setting the remote controller custom code

Use the following steps to select the custom code of the remote controller. (Note that the air conditioner cannot receive a custom code if the air conditioner has not been set for the custom code.)

The custom codes that are set through this process are applicable only to the signal in the function setting.

For details on how to set the custom codes through the normal process, refer to "[Custom code setting](#)" on page 23.

1. Press the SET TEMP. (▲) (▼) buttons to change the custom code between $\text{A} \rightarrow \text{b} \rightarrow \text{c} \rightarrow \text{d}$. Match the code on the display to the air conditioner custom code. (Initially set to A .) If the custom code does not need to be selected, press the MODE button, and proceed to **STEP 2**.
2. Press the MODE button to accept the custom code, and proceed to **STEP 2**.

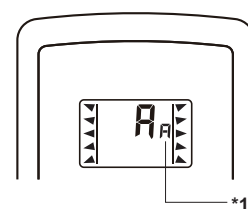

***1:** Small A is displayed on the right of the custom code during the function setting.

NOTES:

- The air conditioner custom code is set to A prior to shipment. To change the custom code, contact your retailer.
- The remote controller resets to custom code A when the batteries on the remote controller are replaced. If you use a custom code other than code A , reset the custom code after replacing the batteries.
- If you do not know the air conditioner custom code setting, try each of the custom codes ($\text{A} \rightarrow \text{b} \rightarrow \text{c} \rightarrow \text{d}$) until you find the code that operates the air conditioner.

STEP 2: Selecting the function number and setting value

1. Press the SET TEMP. (▲) (▼) buttons to select the function number. To switch between the left and right digits, press the MODE button.
2. Press the FAN button to proceed the setting value. To return the function number selection, press the FAN button again.
3. Press the SET TEMP. (▲) (▼) buttons to select the setting value. To switch between the left and right digits, press the MODE button.
4. Press the SLEEP button, then after you hear the beep emitted from the indoor unit, the START/STOP button in the order to confirm the settings.
5. Press the RESET button to cancel the function setting mode.
6. After completing the function setting, be sure to disconnect the power supply and then reconnect it.

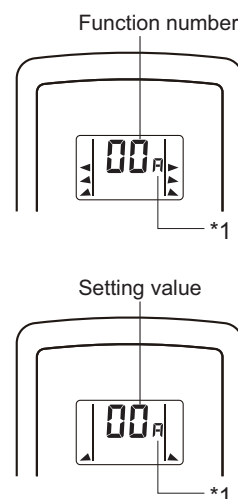

*1: Small  is displayed on the right of the custom code during the function setting.

 CAUTION

After disconnect the power supply, wait 30 seconds or more before reconnecting it. The function setting will not become active unless the power supply is disconnected and then reconnected.

■ Contents of function setting

Each function setting listed in this section is adjustable in accordance with the installation environment.

NOTE: Setting will not be changed if invalid numbers or setting values are selected.

● Function setting list

	Function no.	Functions
1)	11	Filter sign
2)	30/31	Room temperature control for indoor unit sensor
3)	40	Auto restart
4)	42	Room temperature sensor switching
5)	44	Remote controller custom code
6)	46	External input control
7)	48	Room temperature sensor switching (Aux.)
8)	49	Indoor unit fan control for energy saving for cooling

1) Filter sign

Select appropriate intervals for displaying the filter sign on the indoor unit according to the estimated amount of dust in the air of the room.

If the indication is not required, select "No indication" (03).

Function number	Setting value	Setting description	Factory setting
11	00	Standard (400 hours)	
	01	Long interval (1,000 hours)	
	02	Short interval (200 hours)	
	03	No indication	◆

2) Room temperature control for indoor unit sensor

Depending on the installed environment, correction of the room temperature sensor may be required. Select the appropriate control setting according to the installed environment.

The temperature correction values show the difference from the Standard setting "00" (manufacturer's recommended value).

Function number	Setting value	Setting description	Factory setting		
30 (For cooling)	31 (For heating)	00	Standard setting	◆	
		01	No correction 0.0 °C		
		02	-0.5 °C	More cooling Less heating	
		03	-1.0 °C		
		04	-1.5 °C		
		05	-2.0 °C		
		06	-2.5 °C		
		07	-3.0 °C		
		08	-3.5 °C		
		09	-4.0 °C		
		10	+0.5 °C	Less cooling More heating	
		11	+1.0 °C		
		12	+1.5 °C		
		13	+2.0 °C		
		14	+2.5 °C		
		15	+3.0 °C		
		16	+3.5 °C		
17	+4.0 °C				

3) Auto restart

Enables or disables automatic restart after a power interruption.

Function number	Setting value	Setting description	Factory setting
40	00	Enable	◆
	01	Disable	

NOTE: Auto restart is an emergency function such as for power outage etc. Do not attempt to use this function in normal operation. Be sure to operate the unit by remote controller or external device.

4) Room temperature sensor switching

(Only for wired remote controller)

When using the wired remote controller temperature sensor, change the setting to "Both" (01).

Function number	Setting value	Setting description	Factory setting
42	00	Indoor unit	◆
	01	Both	

00: Sensor on the indoor unit is active.

01: Sensors on both indoor unit and wired remote controller are active.

NOTE: Remote controller sensor must be turned on by using the remote controller.

5) Remote controller custom code

(Only for wireless remote controller)

The indoor unit custom code can be changed. Select the appropriate custom code.

Function number	Setting value	Setting description	Factory setting
44	00	A	◆
	01	B	
	02	C	
	03	D	

6) External input control

"Operation/Stop" mode or "Forced stop" mode can be selected.

Function number	Setting value	Setting description	Factory setting
46	00	Operation/Stop mode 1	◆
	01	(Setting prohibited)	
	02	Forced stop mode	
	03	Operation/Stop mode 2	

7) Room temperature sensor switching (Aux.)

To use the temperature sensor on the wired remote controller only, change the setting to "Wired remote controller" (01).

This function will only work if the function setting 42 is set at "Both" (01).

When the setting value is set to "Both" (00), more suitable control of the room temperature is possible by setting function setting 30 and 31 too.

Function number	Setting value	Setting description	Factory setting
48	00	Both	◆
	01	Wired remote controller	

8) Indoor unit fan control for energy saving for cooling

Enables or disables the power-saving function by controlling the indoor unit fan rotation when the outdoor unit is stopped during cooling operation.

Function number	Setting value	Setting description	Factory setting
49	00	Disable	
	01	Enable	◆
	02	Remote controller	

00: When the outdoor unit is stopped, the indoor unit fan operates continuously following the setting on the remote controller.

01: When the outdoor unit is stopped, the indoor unit fan operates intermittently at a very low speed.

02: Enable or disable this function by remote controller setting.

NOTES:

- As the factory setting, this setting is initially activated.
- Set to "00" or "01" when connecting a remote controller that cannot set the Fan control for energy saving function or connecting a network converter.
To confirm if the remote controller has this setting, refer to the operating manual of each remote controller.

9-2. Custom code setting for wireless remote controller

■ Custom code setting

To interconnect the air conditioner and the wireless remote controller, assignment of the custom code for the wireless remote controller is required.

NOTE: Air conditioner cannot receive a custom code if the air conditioner has not been set for the custom code.

1. Press the MODE button for at least 5 seconds to display the current custom code. (Initially set to A .)

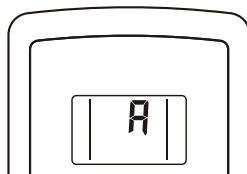





2. Press the SET TEMP. (\blacktriangle or \blacktriangledown) button to change the custom code between $\text{A} \rightarrow \text{b} \rightarrow \text{c} \rightarrow \text{d}$. Match the code on the display to the air conditioner custom code.
3. Press the MODE button again. The custom code will be changed.

NOTES:

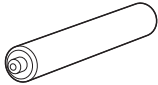

- If no button is pressed within 30 seconds after the custom code is displayed, the system returns to the original clock indicator. In this case, start again from step 1.
- The air conditioner custom code is set to A prior to shipment. To change the custom code, contact your retailer.
- The remote controller resets to custom code A when the batteries in the remote controller are replaced. If you use a custom code other than code A , reset the appropriate custom code after replacing the batteries. If you do not know the assigned code for the air conditioner, try each of the custom code ($\text{A} \rightarrow \text{b} \rightarrow \text{c} \rightarrow \text{d}$) until you find the code which operates the air conditioner.

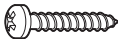
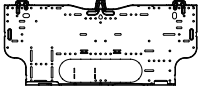
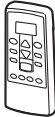
10. Accessories

Part name	Exterior	Q'ty	Part name	Exterior	Q'ty
Operating manual		1	Battery		2
Operating manual (CD-ROM)		1	Cloth tape		1
Installation manual		1	Tapping screw		5
Wall hook bracket		1	Remote controller		1

11. Optional parts

11-1. Others

Exterior	Part name	Model name	Summary
	Remote controller holder	UTZ-RXLA	Wall or pillar mountable, and holds the wireless remote controller.
	Wireless LAN adapter	UTY-TFSXF2	Remotely manage an air conditioning system using mobile devices such as smartphones and tablets.

Part 2. OUTDOOR UNIT

SINGLE TYPE:

ROG07KPCA

ROG09KPCA

ROG12KPCA

1. Specifications

Type			Inverter heat pump		
Model name			ROG07KPCA	ROG09KPCA	ROG12KPCA
Power supply			230 V ~ 50 Hz		
Power supply intake			Outdoor unit		
Available voltage range			198—264 V		
Starting current			A	3.2	3.8
Fan	Airflow rate	Cooling	m ³ /h	1,650	1,650
		Heating		1,450	1,450
	Type × Q'ty	Propeller fan × 1			
Motor output			W	23	
Sound pressure level *1	Cooling	dB (A)	45	47	49
			Heating	46	47
Sound power level	Cooling	dB (A)	57	59	62
			Heating	58	59
Heat exchanger type	Dimensions (H × W × D)		mm	504 × 650 × 18.2	
	Fin pitch			1.3	
	Rows × Stages		1 × 24		2 × 24
	Pipe type		Copper		
	Fin type	Type (Material)	Corrugate (Aluminum)		
Surface treatment		PC Fin			
Compressor	Type × Q'ty		DC Rotary × 1		
	Motor output		W	850	
Refrigerant	Type (Global warming potential)		R32 (675)		
	Charge		g	550	590
Refrigerant oil	Type		POE		
	Amount		cm ³	240	
Enclosure	Material		Steel sheet		
	Color		Beige Approximate color of Munsell 10YR 7.5/1.0		
Dimensions (H × W × D)	Net		mm	541 × 663 × 290	
	Gross			596 × 798 × 369	
Weight	Net		kg	23	25
	Gross			25	27
Connection pipe	Size	Liquid	mm (in)	Ø 6.35 (1/4)	
		Gas		Ø 9.52 (3/8)	
	Method		Flare		
	Pre-charge length		m	15	
	Max. length			20	
Max. height difference		15			
Operation range	Cooling	°C	-10 to 46		
			Heating	-15 to 24	
Drain hose	Material		PP		
	Size		mm Ø 13.0 (I. D.), Ø 16.0 to Ø 16.8 (O. D.)		

NOTES:

- Specifications are based on the following conditions:
 - Cooling: Indoor temperature of 27 °CDB/19 °CWB, and outdoor temperature of 35 °CDB/24 °CWB.
 - Heating: Indoor temperature of 20 °CDB/15 °CWB, and outdoor temperature of 7 °CDB/6 °CWB.
 - Pipe length: 5 m, Height difference: 0 m.
- Protective function might work when using it outside the operation range.
- *1: Sound pressure level
 - Measured values in manufacturer's anechoic chamber.
 - Because of the surrounding sound environment, the sound levels measured in actual installation conditions might be higher than the specified values here.

2. Dimensions

2-1. Models: ROG07KPCA, ROG09KPCA, and ROG12KPCA

Unit: mm

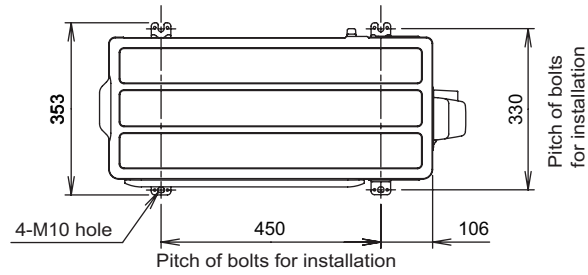

Top view

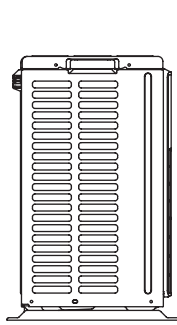

Side view

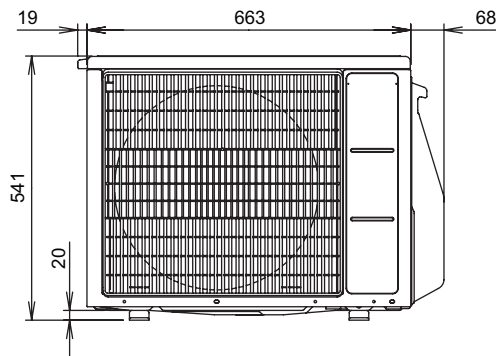

Front view

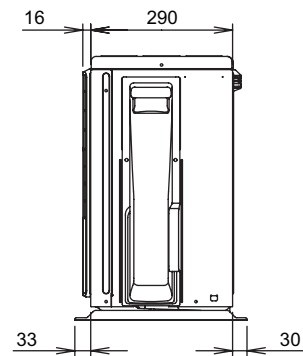

Side view

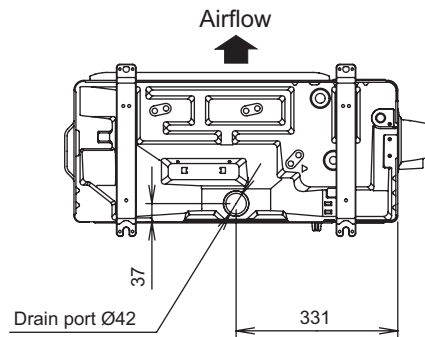

Bottom view

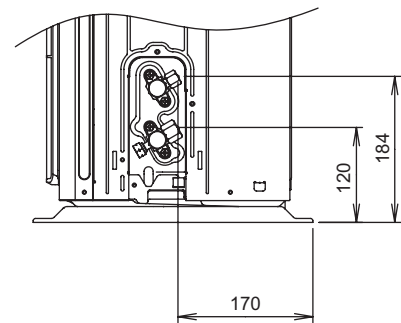

Side view (Valve part)

3. Installation space

3-1. Models: ROG07KPCA, ROG09KPCA, and ROG12KPCA

■ Space requirement

Provide sufficient installation space for product safety.

⚠ CAUTION

Keep the space shown in the installation examples.

If the installation is not performed accordingly, it could cause a short circuit and result in a lack of operating performance.

● Single outdoor unit installation

- When the upper space is open:

Unit: mm

Obstacles at rear only

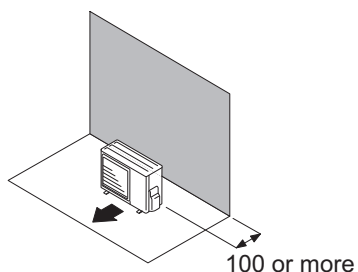

Obstacles at rear and sides

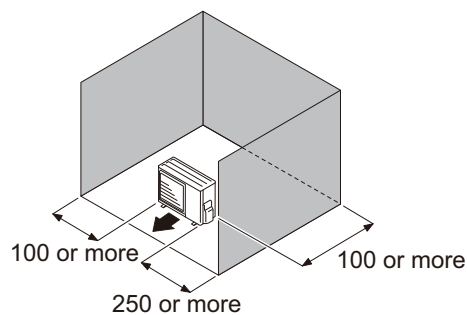

Obstacles at front

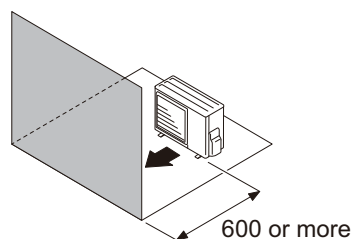

Obstacles at front and rear

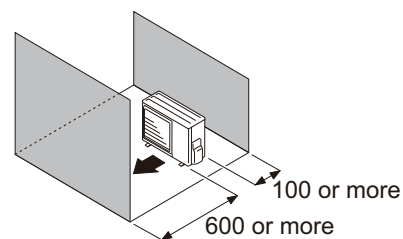

- When there is an obstruction in the upper space:

Unit: mm

Obstacles at rear and above

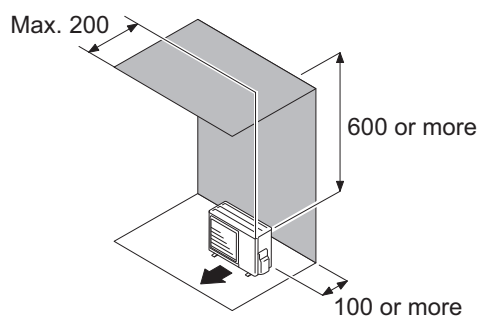

Obstacles at rear, sides, and above

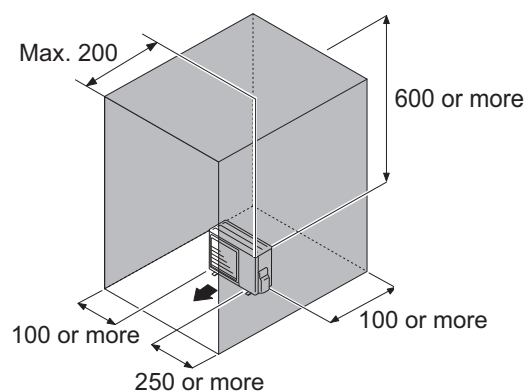

● Multiple outdoor unit installation

- Provide at least 250 mm of space between the outdoor units if multiple units are installed.
- When routing the piping from the side of an outdoor unit, provide space for piping.
- No more than 3 units must be installed side by side.
When 3 units or more are arranged in a line, provide the space as shown in the following example **“When an obstruction in the upper space:”**.

- **When the upper space is open:**

Unit: mm

Obstacles at rear only

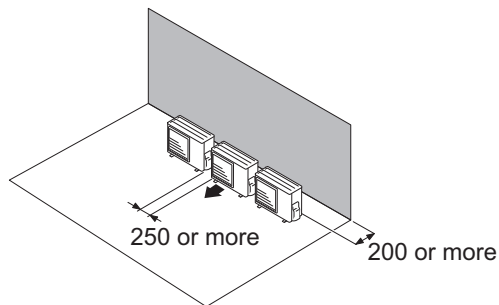

Obstacles at front only

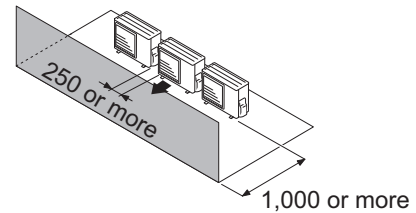

Obstacles at front and rear

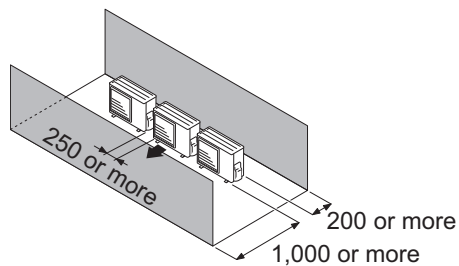

- **When an obstruction in the upper space:**

Unit: mm

Obstacles at rear and above.

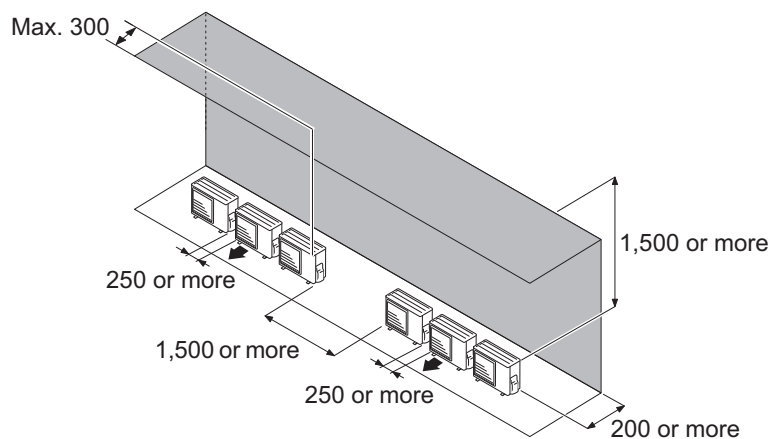

● Outdoor units installation in multi-row

Unit: mm

Single parallel unit arrangement

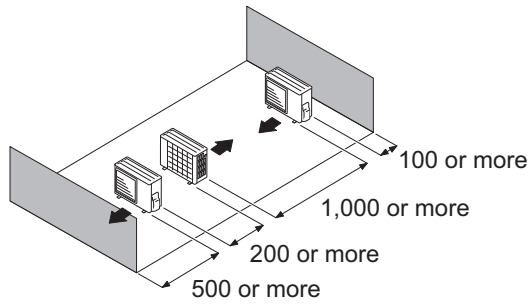

Multiple parallel unit arrangement

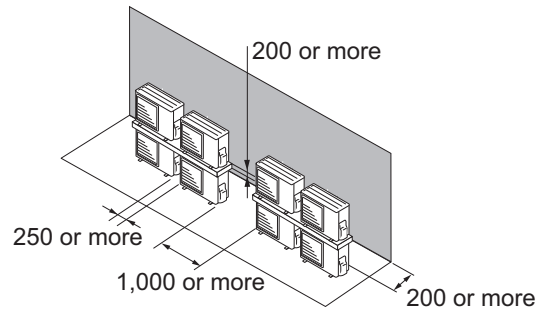
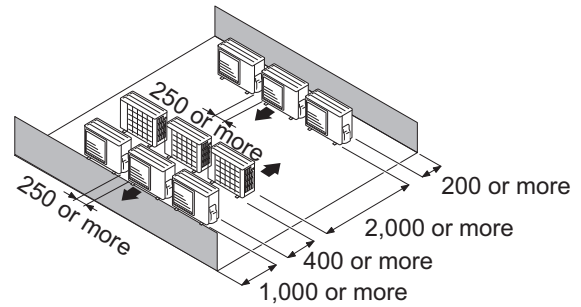

NOTES:

- If the space is larger than stated above, the condition will be the same as when there is no obstacle.
- When installing the outdoor unit, be sure to open the front and left side to obtain better operation efficiency.

⚠ CAUTION

- Do not install the outdoor unit in two-stage where the drain water could freeze. Otherwise the drainage from the upper unit may form ice and cause a malfunction of the lower unit.
- When the outdoor temperature is 0 °C or less, do not use the accessory drain pipe and drain cap. If the drain pipe and drain cap are used, the drain water in the pipe may freeze in extremely cold climate. (For reverse cycle model only.)
- In area with heavy snowfall, if the inlet and outlet of the outdoor unit is blocked with snow, it might become difficult to get warm, and it is likely to cause product malfunction. Construct a canopy and a pedestal, or place the unit on a high stand that is locally installed.

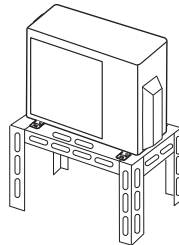

4. Refrigerant circuit

4-1. Models: ROG07KPCA, ROG09KPCA, and ROG12KPCA

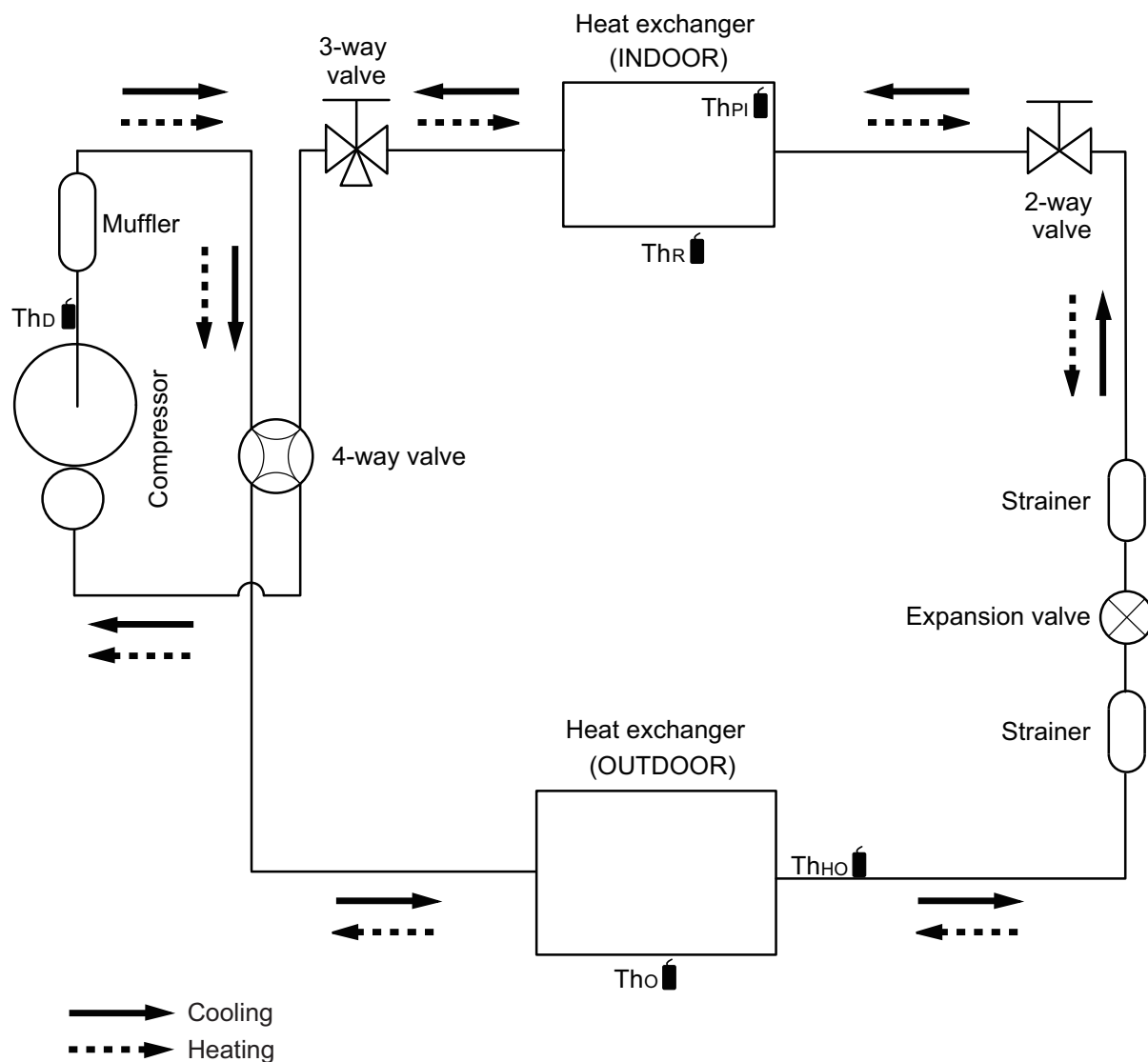

Th_D : Thermistor (Discharge temperature)

Th_O : Thermistor (Outdoor temperature)

Th_{HO} : Thermistor (Heat exchanger out temperature)

Th_R : Thermistor (Room temperature)

Th_{PI} : Thermistor (Pipe temperature)

5. Wiring diagrams

5-1. Models: ROG07KPCA, ROG09KPCA, and ROG12KPCA

OUTDOOR UNIT
ROG07-12KPCA

OUTDOOR UNIT
ROG07-12KPCA

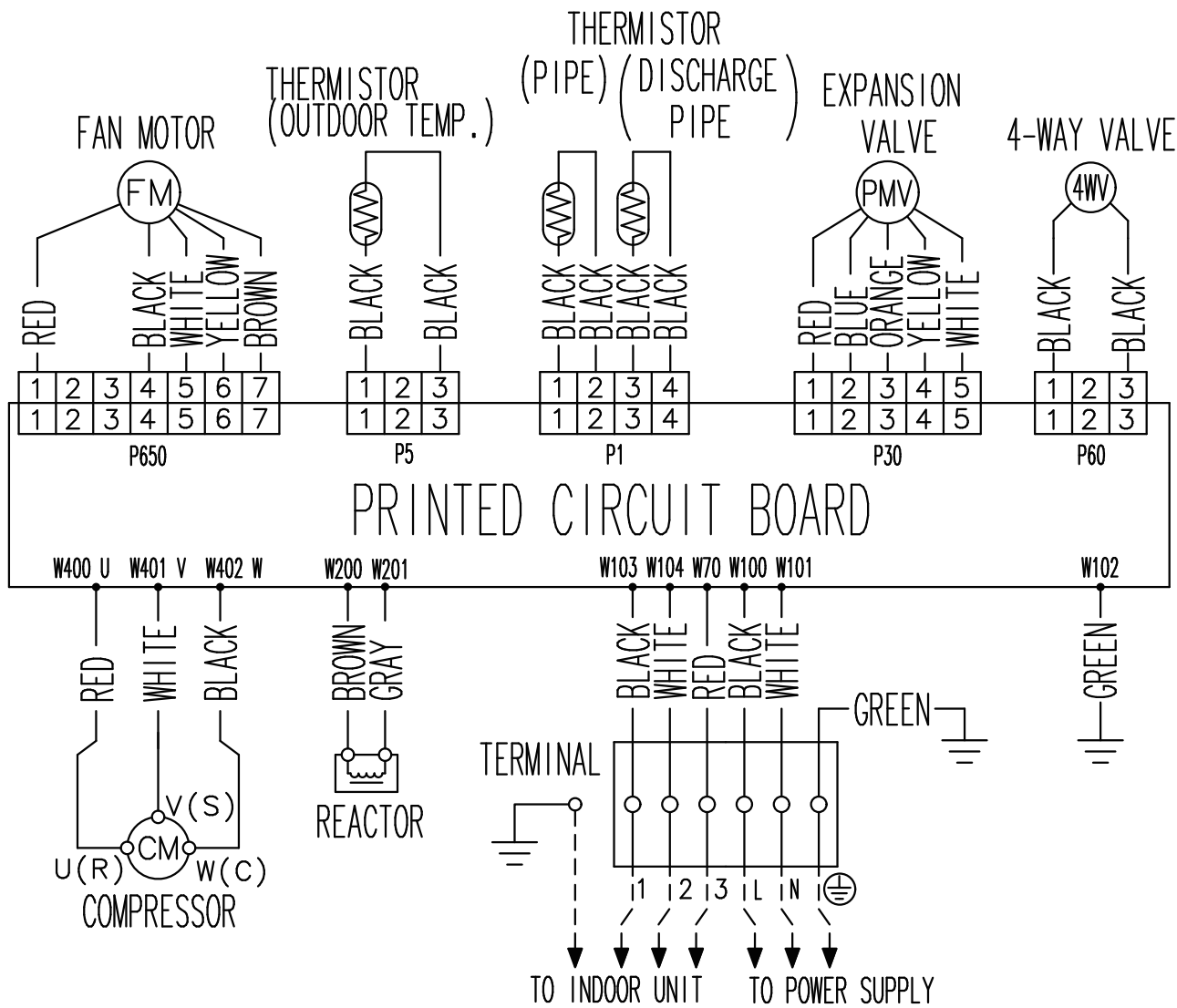

6. Capacity compensation rate for pipe length and height difference

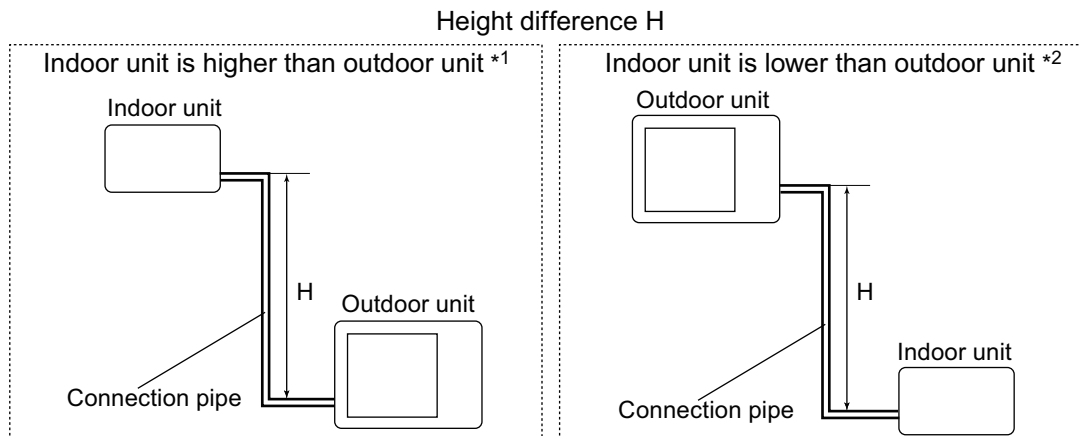

6-1. Models: ROG07KPCA and ROG09KPCA

NOTE: Values mentioned in the table are calculated based on the maximum capacity.

COOLING			Pipe length (m)				
			5	7.5	10	15	20
Height difference H (m)	Indoor unit is higher than outdoor unit *1	15	—	—	—	0.872	0.910
		10	—	—	0.961	0.886	0.925
		7.5	—	0.979	0.965	0.890	0.929
		5	0.992	0.983	0.969	0.893	0.933
	Indoor unit is lower than outdoor unit *2	0	1.000	0.991	0.976	0.901	0.940
		-5	1.000	0.991	0.976	0.901	0.940
		-7.5	—	0.991	0.976	0.901	0.940
		-10	—	—	0.976	0.901	0.940
		-15	—	—	—	0.901	0.940

HEATING			Pipe length (m)				
			5	7.5	10	15	20
Height difference H (m)	Indoor unit is higher than outdoor unit *1	15	—	—	—	0.832	0.822
		10	—	—	0.917	0.832	0.822
		7.5	—	0.961	0.917	0.832	0.822
		5	1.000	0.961	0.917	0.832	0.822
	Indoor unit is lower than outdoor unit *2	0	1.000	0.961	0.917	0.832	0.822
		-5	0.955	0.956	0.912	0.828	0.818
		-7.5	—	0.954	0.910	0.826	0.816
		-10	—	—	0.908	0.824	0.814
		-15	—	—	—	0.815	0.805

6-2. Model: ROG12KPCA

NOTE: Values mentioned in the table are calculated based on the maximum capacity.

COOLING			Pipe length (m)				
			5	7.5	10	15	20
Height difference H (m)	Indoor unit is higher than outdoor unit *1	15	—	—	—	0.858	0.868
		10	—	—	0.929	0.872	0.882
		7.5	—	0.960	0.933	0.876	0.885
		5	0.992	0.964	0.937	0.879	0.889
	Indoor unit is lower than outdoor unit *2	0	1.000	0.972	0.944	0.887	0.896
		-5	1.000	0.972	0.944	0.887	0.896
		-7.5	—	0.972	0.944	0.887	0.896
		-10	—	—	0.944	0.887	0.896
		-15	—	—	—	0.887	0.896

HEATING			Pipe length (m)				
			5	7.5	10	15	20
Height difference H (m)	Indoor unit is higher than outdoor unit *1	15	—	—	—	0.896	0.879
		10	—	—	0.968	0.890	0.879
		7.5	—	0.994	0.968	0.896	0.879
		5	1.000	0.994	0.968	0.896	0.879
	Indoor unit is lower than outdoor unit *2	0	1.000	0.994	0.968	0.896	0.879
		-5	0.995	0.989	0.963	0.891	0.875
		-7.5	—	0.987	0.961	0.889	0.873
		-10	—	—	0.959	0.887	0.871
		-15	—	—	—	0.878	0.862

7. Additional charge calculation

7-1. Models: ROG07KPCA and ROG09KPCA

Refrigerant type		R32
Refrigerant amount	g	550

■ Refrigerant charge

Total pipe length	m	15 or less	20 (Max.)	20 g/m
Additional charge	g	0	100	

7-2. Model: ROG12KPCA

Refrigerant type		R32
Refrigerant amount	g	590

■ Refrigerant charge

Total pipe length	m	15 or less	20 (Max.)	20 g/m
Additional charge	g	0	100	

8. Airflow

8-1. Model: ROG07KPCA

● Cooling

Airflow	
m ³ /h	1,650
l/s	458
CFM	971

● Heating

Airflow	
m ³ /h	1,450
l/s	403
CFM	853

8-2. Model: ROG09KPCA

● Cooling

Airflow	
m ³ /h	1,650
l/s	458
CFM	971

● Heating

Airflow	
m ³ /h	1,450
l/s	403
CFM	853

8-3. Model: ROG12KPCA

● Cooling

Airflow	
m ³ /h	1,700
l/s	472
CFM	1,001

● Heating

Airflow	
m ³ /h	1,470
l/s	408
CFM	865

9. Operation noise (sound pressure)

9-1. Noise level curve

Model: ROG07KPCA

Cooling

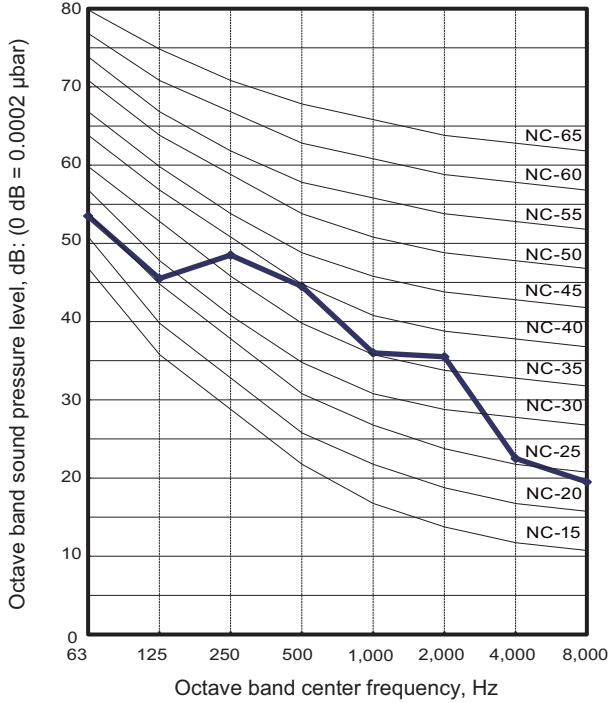

Heating

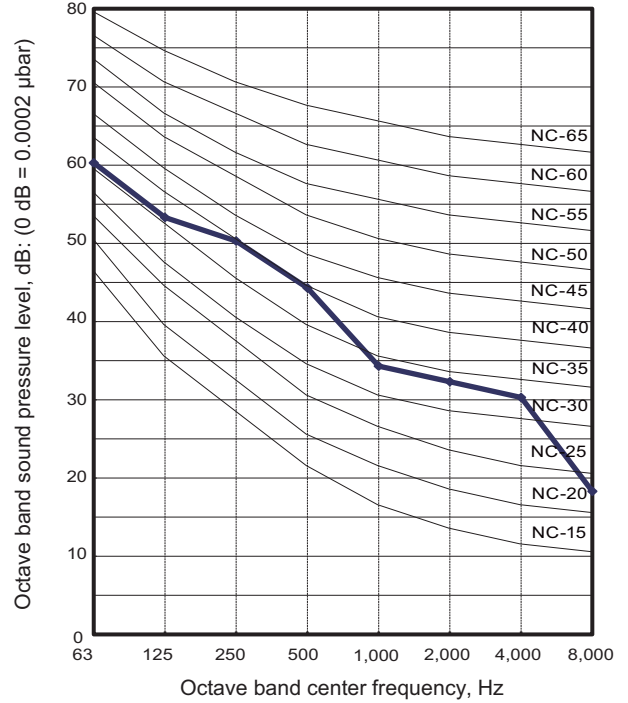

Model: ROG09KPCA

Cooling

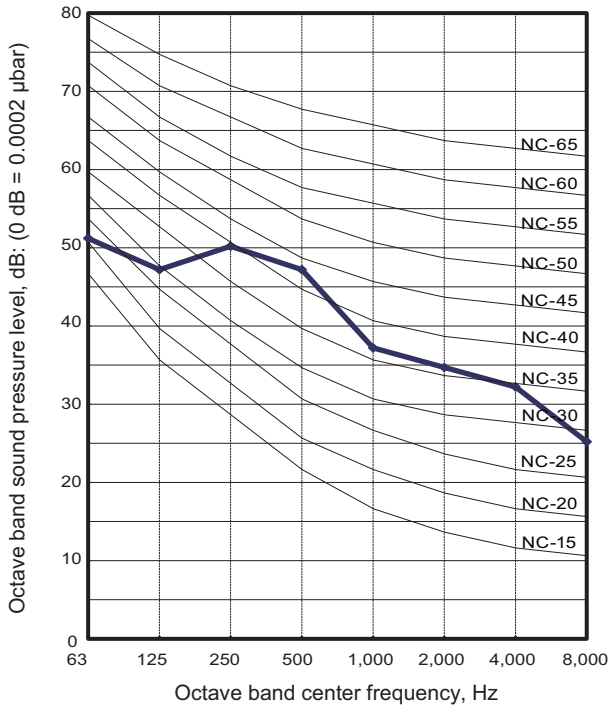

Heating

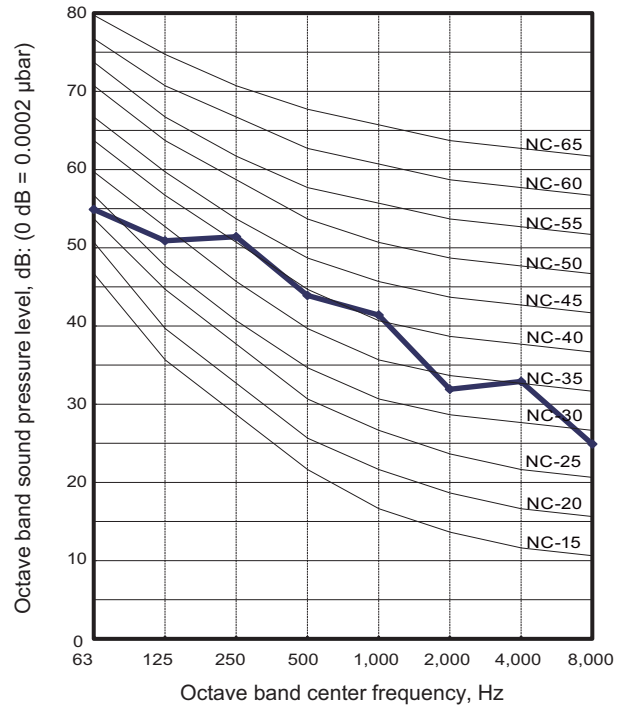

OUTDOOR UNIT
ROG07-12KPCA

OUTDOOR UNIT
ROG07-12KPCA

Model: ROG12KPCA

Cooling

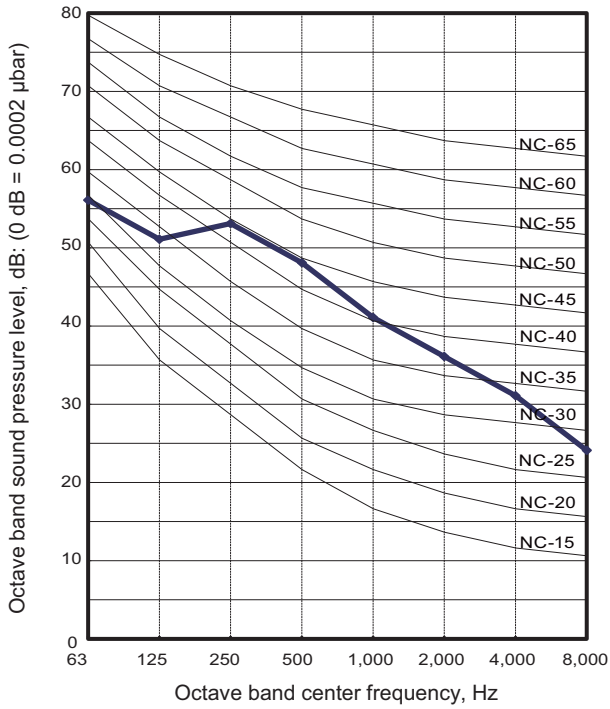

Heating

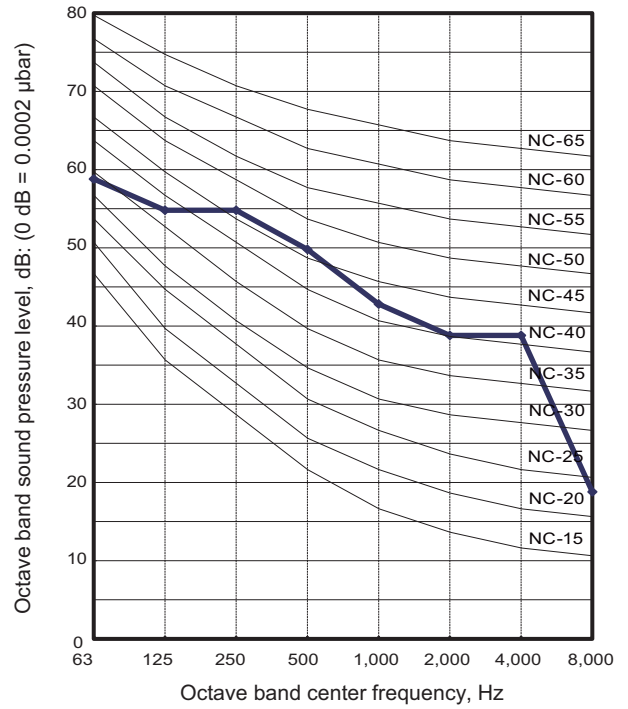

OUTDOOR UNIT
ROG07-12KPCA

OUTDOOR UNIT
ROG07-12KPCA

9-2. Sound level check point

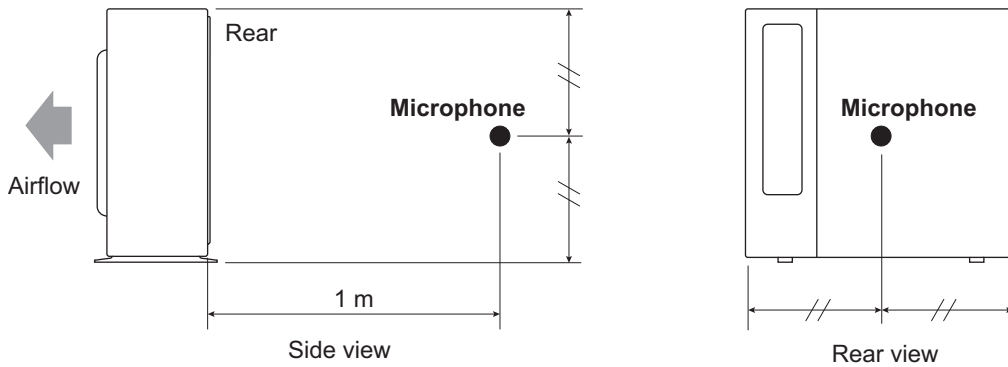

NOTE: Detailed shape of the actual outdoor unit might be slightly different from the one illustrated above.

10. Electrical characteristics

Model name			ROG07KPCA	ROG09KPCA	ROG12KPCA
Power supply	Voltage	V	230 ~		
	Frequency	Hz	50		
Max operating current *1		A	9.0	9.0	9.0
Starting current		A	3.2	3.8	5.6
Wiring spec. *2	Circuit breaker current		A	15	
	Power cable		mm ²	1.5	
	Connection cable *3	Cross-sectional area	mm ²	1.5	
		Limited wiring length	m	21	

*1: Maximum operating current is the total current of the indoor unit and the outdoor unit.

*2: Selected sample based on Japan Electrotechnical Standards and Codes Committee E0005. As the regulations of wire size and circuit breaker differ in each country or region, select appropriate devices complied to the regional standard.

*3: Limit voltage drop to less than 2%. If voltage drop is 2% or more, increase cable conductor size.

11. Safety devices

Type of protection	Protection form		Model		
			ROG07KPCA	ROG09KPCA	ROG12KPCA
Circuit protection	Current fuse (Main PCB)		250 V, 20 A 250 V, 5 A		
Fan motor protection	Thermistor protection	Activate	85—122 °C Fan motor stop		
		Reset	77—114 °C Fan motor restart		
Compressor protection	Terminal protection program (Discharge temp.)	Activate	110 °C Compressor stop		
		Reset	After 7 minutes Compressor restart		
	Thermal protection program (Outdoor temp.)	Activate	COOL or DRY: -15 °C HEAT: -20 °C Compressor stop		
		Reset	COOL or DRY: -10 °C HEAT: -15 °C Compressor restart		

12. Accessories

12-1. Models: ROG07KPCA, ROG09KPCA, and ROG12KPCA

Part name	Exterior	Q'ty	Part name	Exterior	Q'ty
Drain pipe		1			